



User Manual

Sound Level Meter Calibrator PCE-SC 10



User manuals in various languages (français, italiano, español, português, nederlands, türk, polski, русский, 中文) can be found by using our product search on: www.pce-instruments.com

Last change: 8 February 2018
v1.0



Contents

1	Safety notes	1
2	Introduction	2
3	Applications.....	2
4	Features	2
5	Functional block diagram	2
6	Information on calibration principle.....	3
7	Operation	3
8	Technical specifications	3
9	Delivery contents	3
10	Warranty.....	4
11	Disposal	4

1 Safety notes

Please read this manual carefully and completely before you use the device for the first time. The device may only be used by qualified personnel and repaired by PCE Instruments personnel. Damage or injuries caused by non-observance of the manual are excluded from our liability and not covered by our warranty.

- The device must only be used as described in this instruction manual. If used otherwise, this can cause dangerous situations for the user and damage to the meter.
- The instrument may only be used if the environmental conditions (temperature, relative humidity, ...) are within the ranges stated in the technical specifications. Do not expose the device to extreme temperatures, direct sunlight, extreme humidity or moisture.
- Do not expose the device to shocks or strong vibrations.
- The case should only be opened by qualified PCE Instruments personnel.
- Never use the instrument when your hands are wet.
- You must not make any technical changes to the device.
- The appliance should only be cleaned with a damp cloth. Use only pH-neutral cleaner, no abrasives or solvents.
- The device must only be used with accessories from PCE Instruments or equivalent.
- Before each use, inspect the case for visible damage. If any damage is visible, do not use the device.
- Do not use the instrument in explosive atmospheres.
- The measurement range as stated in the specifications must not be exceeded under any circumstances.
- Non-observance of the safety notes can cause damage to the device and injuries to the user.

We do not assume liability for printing errors or any other mistakes in this manual.

We expressly point to our general guarantee terms which can be found in our general terms of business.

If you have any questions please contact PCE Instruments. The contact details can be found at the end of this manual.



2 Introduction

The PCE-SC 10 is a class 1 acoustic calibrator used for the calibration of microphones, sound pressure level (SPL) meters and other noise meters. The sound calibrator is suitable for use with type 1 or class I noise measuring instruments. This portable decibel (db) meter calibrator is easy to use in the field or in laboratories.

3 Applications

- Calibration of microphones, sound level meters and other sound measurement equipment
- Check the linearity of the equipment to be calibrated

4 Features

- Complies with IEC60942:2003 Class 1, ANSI S1.40-1984 and GB/T 15173-1994
- 1 kHz calibration frequency for all weighting networks
- Dual 94 & 114 dB sound pressure level outputs
- Calibration accuracy ± 0.3 dB
- Highly stable level and frequency
- Easy 2-key operation
- Fits 1/2" microphones and 1/4" microphones (with adaptor)
- Powered by 2xAA batteries and automatic power off to conserve battery life

5 Functional block diagram

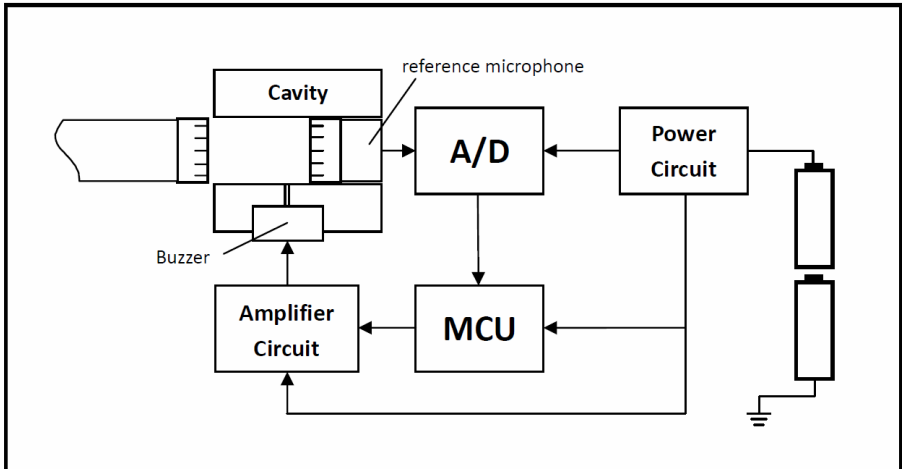

6 Information on calibration principle

The PCE-SC 10 sound calibrator is a battery operated sound source for quick and direct calibration of sound level meters and other sound measuring systems. It fits 1/2" microphones and 1/4" microphones (with adaptors). The calibration frequency is 1000 Hz, which is the reference frequency for the standardized international weighting networks. That enables you to use the calibrator for calibrating sound equipment with A, B, C, D weighting filters and linear. The calibration pressure is 94 ± 0.3 dB (1 Pa) and 114 ± 0.3 dB (10 Pa). The PCE-SC 10 is equipped with a feed-back arrangement to ensure a highly stable sound pressure level. The feed-back loop contains a reference microphone, a sound source and control circuit. The reference microphone has passed a long-term aging test and has proved to be extremely stable. The feed-back control circuit can adjust for changes in load volume, temperature, humidity and atmospheric pressure. The calibrator gives a continuous sound pressure level when fitted onto a microphone and detects when the microphone is removed from the cavity and automatically switched off, thereby extending the battery life. When the ON/OFF light flashes, this means that the battery voltage is low. If the device stops working continuously, the batteries must be replaced.

7 Operation

- Pull down the battery compartment cover and insert the batteries. Make sure the polarity is correct.
- Switch on the calibrator as well as the device to be calibrated (On / off key). Set either 94 or 114 dB, using the change key.
- Place the aperture of the calibrator on the microphone (use the adaptor if applicable).
- A value now appears in the display of the sound level meter. When this value has stabilised, turn the calibration screw to adjust the value accordingly.

8 Technical specifications

Frequency	1 kHz / ± 0.5 %
Sound pressure levels	94 dB and 114 dB
Accuracy	± 0.3 dB
Sound distortion	<2 %
Stabilization time	<10 s
Microphone aperture	1/2" and 1/4" according to IEC 61094-4
Operating conditions	-10 ... +50 °C (+10 ... +122 °F) 10 ... 90 % RH
Power supply	2 x 1.5 V AA batteries (LR6)
Dimensions	75 x 70 x 46 mm (2.96 x 2.76 x 1.82")
Weight	316 g (0.7 lb)

9 Delivery contents

- 1 x sound calibrator PCE-SC 10
- 2 x 1.5 V AA battery (LR6)
- 1 x adaptor



10 Warranty

You can read our warranty terms in our General Business Terms which you can find here: <https://www.pce-instruments.com/english/terms>.

11 Disposal

For the disposal of batteries in the EU, the 2006/66/EC directive of the European Parliament applies. Due to the contained pollutants, batteries must not be disposed of as household waste. They must be given to collection points designed for that purpose.

In order to comply with the EU directive 2012/19/EU we take our devices back. We either re-use them or give them to a recycling company which disposes of the devices in line with law.

For countries outside the EU, batteries and devices should be disposed of in accordance with your local waste regulations.

If you have any questions, please contact PCE Instruments.



PCE Instruments contact information

Germany

PCE Deutschland GmbH
Im Langel 4
D-59872 Meschede
Deutschland
Tel.: +49 (0) 2903 976 99 0
Fax: +49 (0) 2903 976 99 29
info@pce-instruments.com
www.pce-instruments.com/deutsch

France

PCE Instruments France EURL
23, rue de Strasbourg
67250 SOULTZ-SOUS-FORETS
France
Téléphone: +33 (0) 972 3537 17
Numéro de fax: +33 (0) 972 3537 18
info@pce-france.fr
www.pce-instruments.com/french

Spain

PCE Ibérica S.L.
Calle Mayor, 53
02500 Tobarra (Albacete)
España
Tel. : +34 967 543 548
Fax: +34 967 543 542
info@pce-iberica.es
www.pce-instruments.com/espanol

United States of America

PCE Americas Inc.
711 Commerce Way suite 8
Jupiter / Palm Beach
33458 FL
USA
Tel: +1 (561) 320-9162
Fax: +1 (561) 320-9176
info@pce-americas.com
www.pce-instruments.com/us

United Kingdom

PCE Instruments UK Ltd
Units 12/13 Southpoint Business Park
Ensign Way, Southampton
Hampshire
United Kingdom, SO31 4RF
Tel: +44 (0) 2380 98703 0
Fax: +44 (0) 2380 98703 9
info@industrial-needs.com
www.pce-instruments.com/english

Italy

PCE Italia s.r.l.
Via Pesciatina 878 / B-Interno 6
55010 LOC. GRAGNANO
CAPANNORI (LUCCA)
Italia
Telefono: +39 0583 975 114
Fax: +39 0583 974 824
info@pce-italia.it
www.pce-instruments.com/italiano

The Netherlands

PCE Brookhuis B.V.
Institutenweg 15
7521 PH Enschede
Nederland
Telefoon: +31 (0)53 737 01 92
Fax: +31 53 430 36 46
info@pcebenelux.nl
www.pce-instruments.com/dutch

Chile

PCE Instruments Chile S.A.
RUT: 76.154.057-2
Santos Dumont 738, local 4
Comuna de Recoleta, Santiago, Chile
Tel. : +56 2 24053238
Fax: +56 2 2873 3777
info@pce-instruments.cl
www.pce-instruments.com/chile

Hong Kong

PCE Instruments HK Ltd.
Unit J, 21/F., COS Centre
56 Tsun Yip Street
Kwun Tong
Kowloon, Hong Kong
Tel: +852-301-84912
jji@pce-instruments.com
www.pce-instruments.cn

China

PCE (Beijing) Technology Co.,Ltd
1519 Room, 6 Building
Men Tou Gou Xin Cheng,
Men Tou Gou District
102300 Beijing
China
Tel: +86 (10) 8893 9660
info@pce-instruments.cn
www.pce-instruments.cn

Turkey

PCE Teknik Cihazları Ltd.Şti.
Halkalı Merkez Mah.
Pehlivan Sok. No.6/C
34303 Küçükçekmece - İstanbul
Türkiye
Tel: 0212 471 11 47
Faks: 0212 705 53 93
info@pce-cihazlari.com.tr
www.pce-instruments.com/turkish