



PCE Americas Inc.
711 Commerce Way
Suite 8
Jupiter
FL-33458
USA
From outside US: +1
Tel: (561) 320-9162
Fax: (561) 320-9176
info@pce-americas.com

PCE Instruments UK Ltd.
Units 12/13
Southpoint Business Park
Ensign way
Hampshire / Southampton
United Kingdom, SO31 4RF
From outside UK: +44
Tel: (0) 2380 98703 0
Fax: (0) 2380 98703 9
info@industrial-needs.com

www.pce-instruments.com/english
www.pce-instruments.com

HiBestViewer User Guide

High-Speed Camera

PCE-HSC 1660



Table of Contents

Chapter 1 Getting Started/Overview	3
1 Acquire View	3
2 Strip View	4
3 Working View	5
Chapter 2 Install <i>HiBestViewer</i>	7
1 Installation Environment.....	7
2 Install <i>HiBestViewer</i> Software Suite	7
3 Install High Speed Camera driver.....	9
4 Uninstall <i>HiBestViewer</i> Software Suite	9
Chapter 3 Acquire View, Capture Series Images	11
1 Install High-Speed Camera	11
2 Start up <i>HiBestViewer</i>	11
3 Acquire View Function Description	13
Chapter 4 Strip View, Browse and View Images	22
1 How to switch to Strip View	22
2 Strip View Static Information	23
3 Strip ViewAuxiliary	24
4 Save a series of images as general-purpose video file.....	30
5 Context Menu Function within Image Thumbnails	32
6 Switch from Strip View to Working View	35
Chapter 5 Working View, Further Examinnng and Processing.....	36
1 How to switch to Working View	36
2 Play Control	37
3 Other functions in Woking View.....	42
Chater 6 Hardware Installation	47
1. Installing the Camera	47

Copyright

All rights reserved. Without the prior permission of the company, no part of this user guide may be reproduced, adapted, transcribed, or copied.

The trademarks and product names mentioned in this user guide are legally registered to their respective companies. The usage of this user guide is described for “High-Speed Camera”. Our company makes no representation or warranties, either expressed or implied, with respect to the contents hereof and specifically disclaims any warranties, merchantability or fitness for any particular purpose.

Further, our company reserves the right to revise this publication and to make changes from time to time in the contents hereof without obligation of our company to notify any person of such revision or changes.

This user guide is protected by copyright laws. All copyrights are reserved by our company. Without prior permission, no part of this user guide may be reproduced, copied, transmitted, adapted, photographed, or transcribed. Any infringement of copyright will not be tolerated by our company.

Disclaimer

Our company make no warranty of any kind with regard to the content of this user guide, and the content of this user guide is subject to be revised without prior notice. We will not take the responsibility including any compensation for any mistake found in this user guide.

Chapter 1 Getting Started/Overview

HiBestViewer is Software Suite applied for PC control, and the feature descriptions are as follows:

1. *HiBestViewer* is PC control software, also the accompanying software to the “High-Speed Camera” PCE-HSC 1660 (Except others are not supported by *HiBestViewer*).
2. *HiBestViewer*, Windows Program, should be installed in Windows 7 and latest Windows OS version or above.
3. At least 2GB RAM is recommended, so 64-bit PC and 64-bit version Windows OS are recommended to run *HiBestViewer*.

Main functions for *HiBestViewer* are classified as below:

- (1) Acquire View (2) Strip View (3) Working View

1 Acquire View

Help user capture images, and Acquire View functions are as follows:

- 1.1 Automatically connect to “High-Speed Camera” PCE-HSC 1660 from PC, and it is listed on the context menu.
- 1.2 User can select “High-Speed Camera” PCE-HSC 1660 on the context menu.
- 1.3 Adjust camera’s capture setting, e.g.: resolution, exposure time and gain.
- 1.4 Preview used to capture images and displayed on PC screen, is to make sure the images are confirmed, and also the preparation is ready before storing.
- 1.5 Trigger is to start storing image, and user can set up “the number of images can be stored” before trigger.
- 1.6 Figure 1-1 is Acquire View :

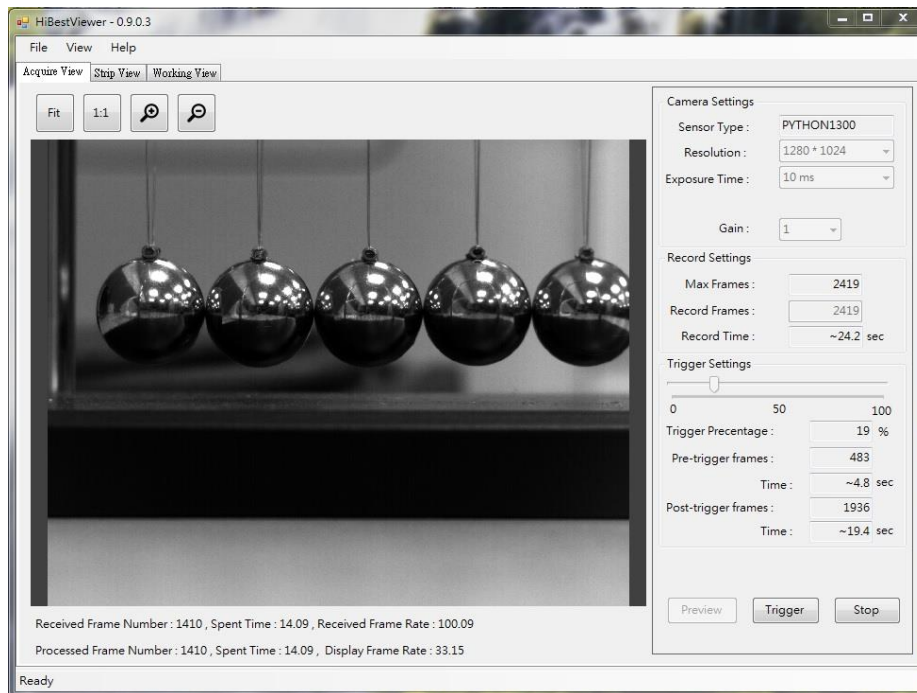

Figure 1-1 Acquire View

2 Strip View

Help user view a series of stored images, and Strip View functions are as follows:

- 2.1 Quickly browse all of series images in order to find out the key images segment.
 - 2.1.1 Provide image thumbnails and display a series of image thumbnails at one time for user to view images.
 - 2.1.2 Provide the function of zoom in/out for user to adjust images range if necessary.
 - 2.1.3 Provide frame number and time (unit: micro-second) for user to realize “the sequence of serial images and the range of a certain segment”.
- 2.2 User can preview a specified image by selecting its thumbnail for detail inspection.
- 2.3 Mark the specified image thumbnails:
 - 2.3.1 Set the specified image as the origin of the coordinates (Frame number 0).
 - 2.3.2 Set A-B play range as the start point (A point) or the end point (B point).
- 2.4 Display basic information about a series of images, e.g.: total number of images, frame rate and image resolution when capturing.
- 2.5 Save a series of images as general-purpose video file or image file, e.g.: MP4, Mpeg2, and Bmp.
- 2.6 Figure 1-2 is StripView :

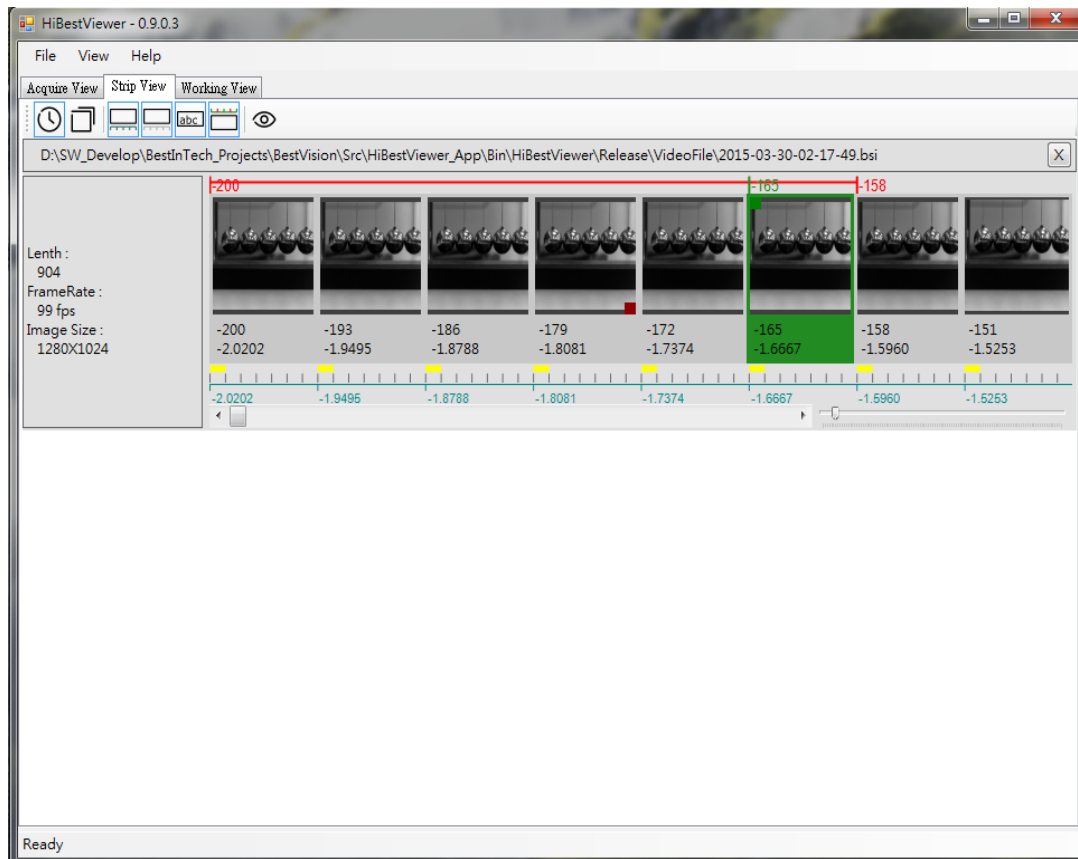

Figure 1-2 Strip View

3 Working View

Help user play back a series of stored images, and Working View functions are as follows:

- 3.1 Versatile play back:
 - 3.1.1 Play forward.
 - 3.1.2 Play backward.
 - 3.1.3 Play one step forward.
 - 3.1.4 Play one step backward.
 - 3.1.5 Back to the start point.
 - 3.1.6 Forward to the end point.
 - 3.1.7 Replay in loop.
- 3.2 Set A and B point of A-B play back range.
- 3.3 Set the specified image as the origin image (Frame number 0).
- 3.4 Set the play interval. It indicates how many images will be skipped between current to the next image during play back.
- 3.5 Set up the play back speed.
- 3.6 Set a Bookmark to the image or remove Bookmark.
- 3.7 Set a comment to the image or remove comment.
- 3.8 Provide coordinate information of a specified position within image (using mouse to click or drag to specify the position).
- 3.9 Figure 1-3 WorkingView :

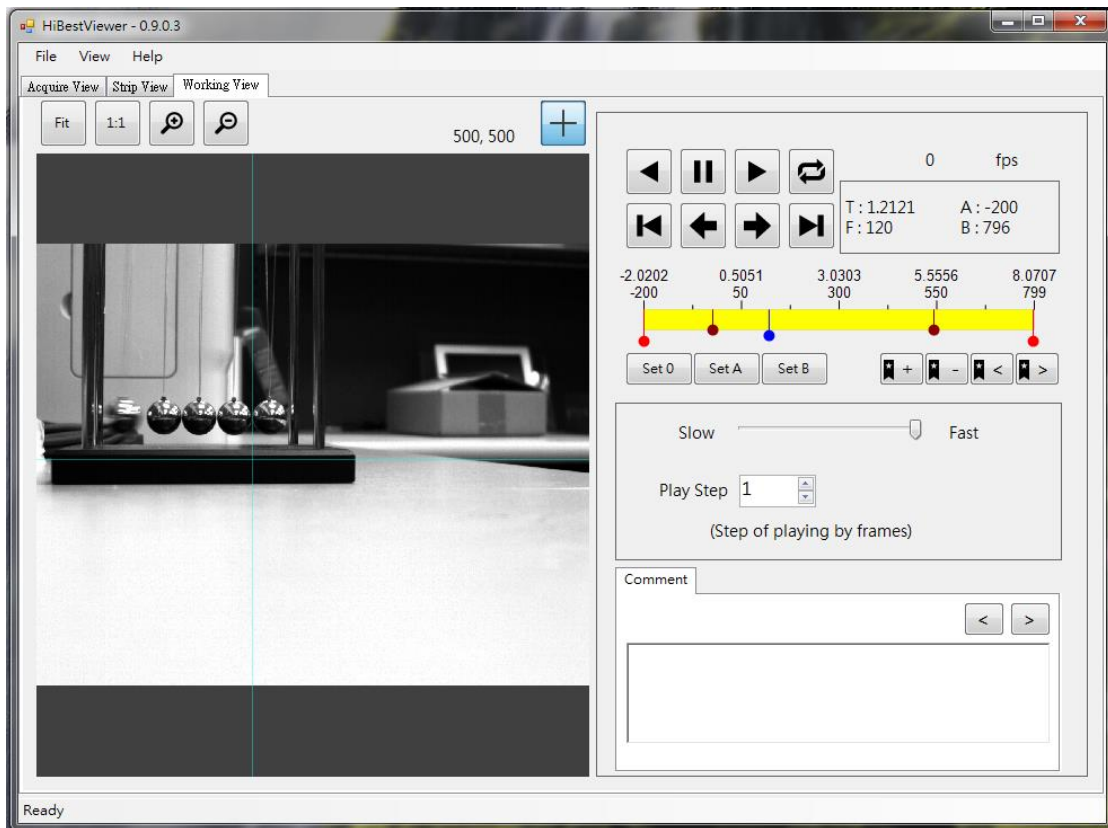

Figure 1-3 Working View

Chapter 2 Install *HiBestViewer*

1 Installation Environment

1.1 PC Hardware Equipments:

- 1.1.1 CPU speed should be more than or equal to 2.0 GHz, and Intel 64-bit CPU is recommended.
- 1.1.2 At least one or more USB 3.0 port, and Intel USB 3.0 host controller is recommended.
- 1.1.3 RAM should be more than or equal to 2GB.
- 1.1.4 Hard disk capacity should be more than or equal to 512MB.

1.2 OS Environment:

- 1.2.1 Windows 7 or above Windows version
- 1.2.2 Windows 64-bit version is recommended
- 1.2.3 Run “Windows Update” and install all important patches to Windows (Based on PC updating condition, it may need more than one time to update).

2 Install *HiBestViewer* Software Suite

- 2.1 Turn on PC, insert the setup CD that contains *HiBestViewer* Software Suite into the CD-ROM drive, and run “setup.exe”.
- 2.2 After “setup.exe” running, user may view Figure 2-1 or Figure 2-2 (version number may be different). If see Figure 2-2, it means that user has installed *HiBestViewer* Software Suite before.

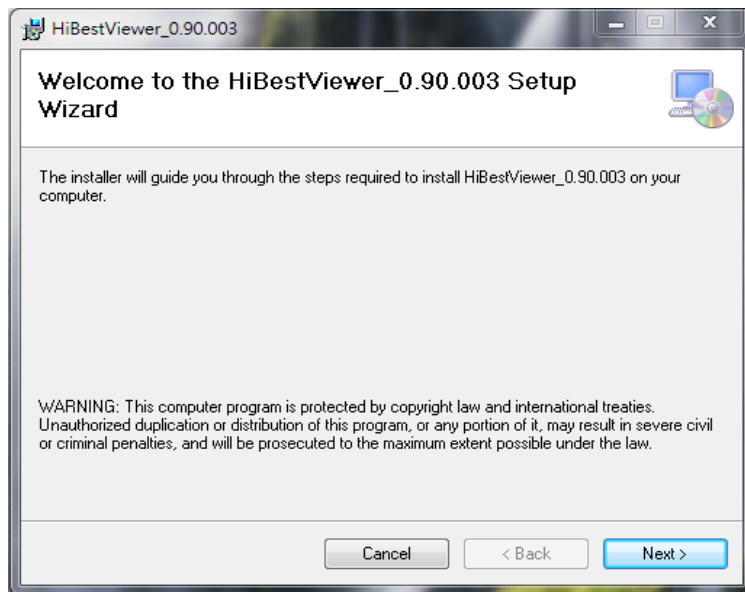

Figure 2-1 Setup starting

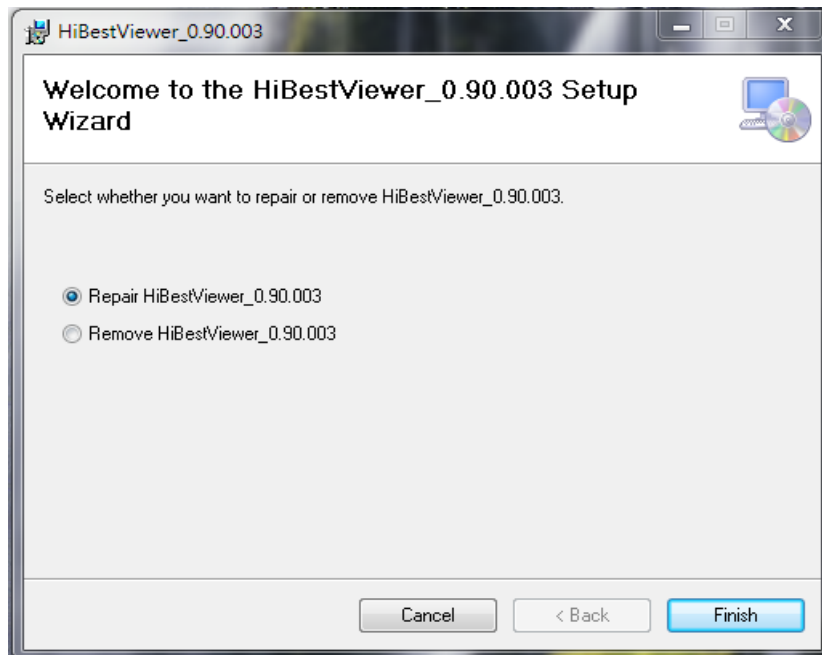

Figure 2-2 Once installed *HiBestViewer* Setup
(If selecting “Repair *HiBestViewer*”, it will be re-installed; if selecting “Remove *HiBestViewer*”, it will be removed.)

- 2.3 User follow prompts on the setup screen to complete installation.
- 2.4 When *HiBestViewer* is installed, *HiBestViewer* shortcut will be shown on the desktop (See Figure 2-3), and also Windows Programs will create a *HiBestViewer* Program Folder (See Figure 2-4).

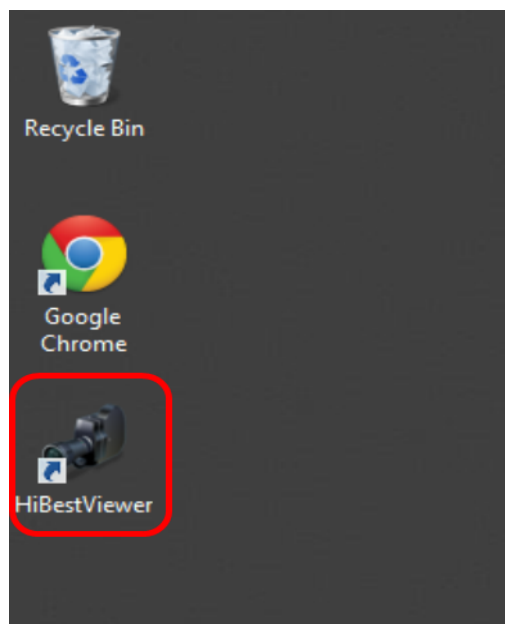

Figure 2-3 *HiBestViewer* shortcut on PC Screen

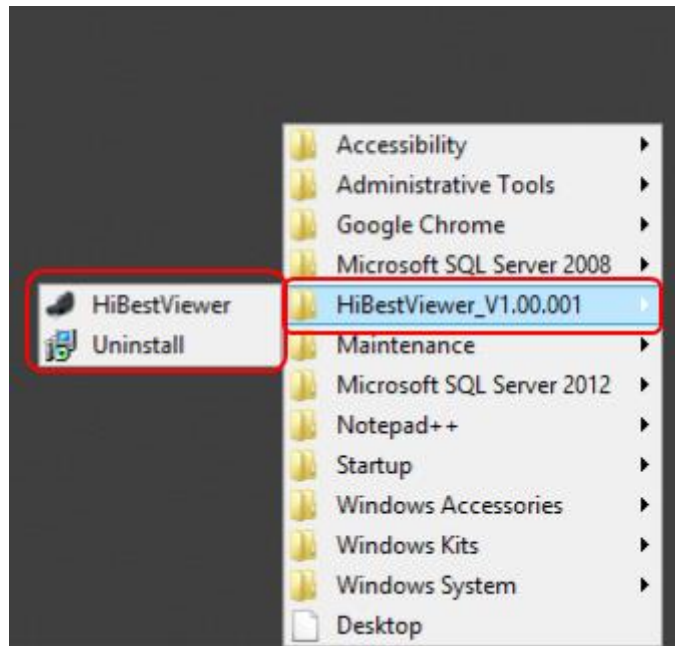

Figure 2-4 *HiBestViewer* Program Folder in Windows Programs

2.5 Attention! Do not install *HiBestViewer* in “Windows” or “Program Files” or “Program Files (x86)”. Because in these folders, it is not allowed to create folders or files unless user owns “administrator privileged”, this restriction will cause the main functions of *HiBestViewer* out of work.

2.6 Attention! *HiBestViewer* setup program does not install driver; in other words, “High-Speed Camera” is required to install driver individually.

3 Install High Speed Camera driver

3.1 Insert the setup CD and run

“Setup_USB_Driver\Setup_BestInc_USB_Driver.exe”.

3.2 User can follow prompts on the setup screen to complete installation.

4 Uninstall *HiBestViewer* Software Suite

If want to remove *HiBestViewer*, user can run Uninstall program in *HiBestViewer* Program Folder (See Figure 2-5), or “Programs and Features” via the Control Panel (See Figure 2-6).

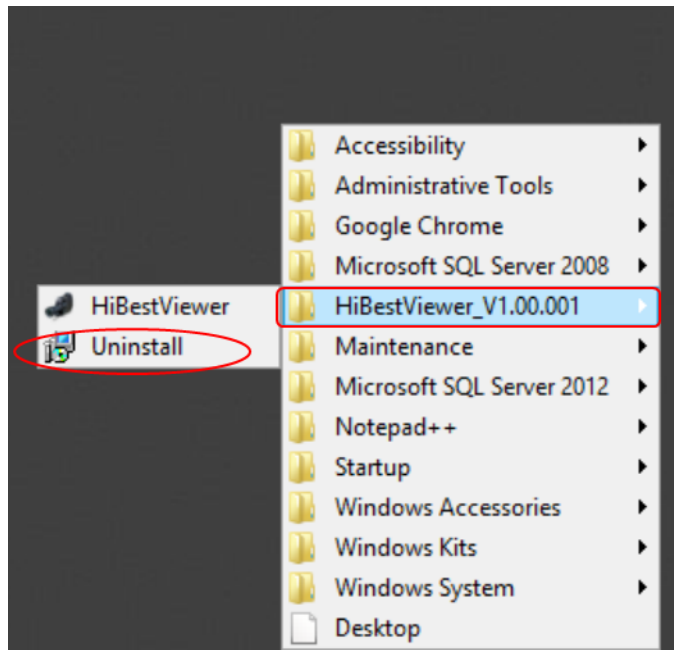

Figure 2-5 Uninstall Program in *HiBestViewer* Program Folder

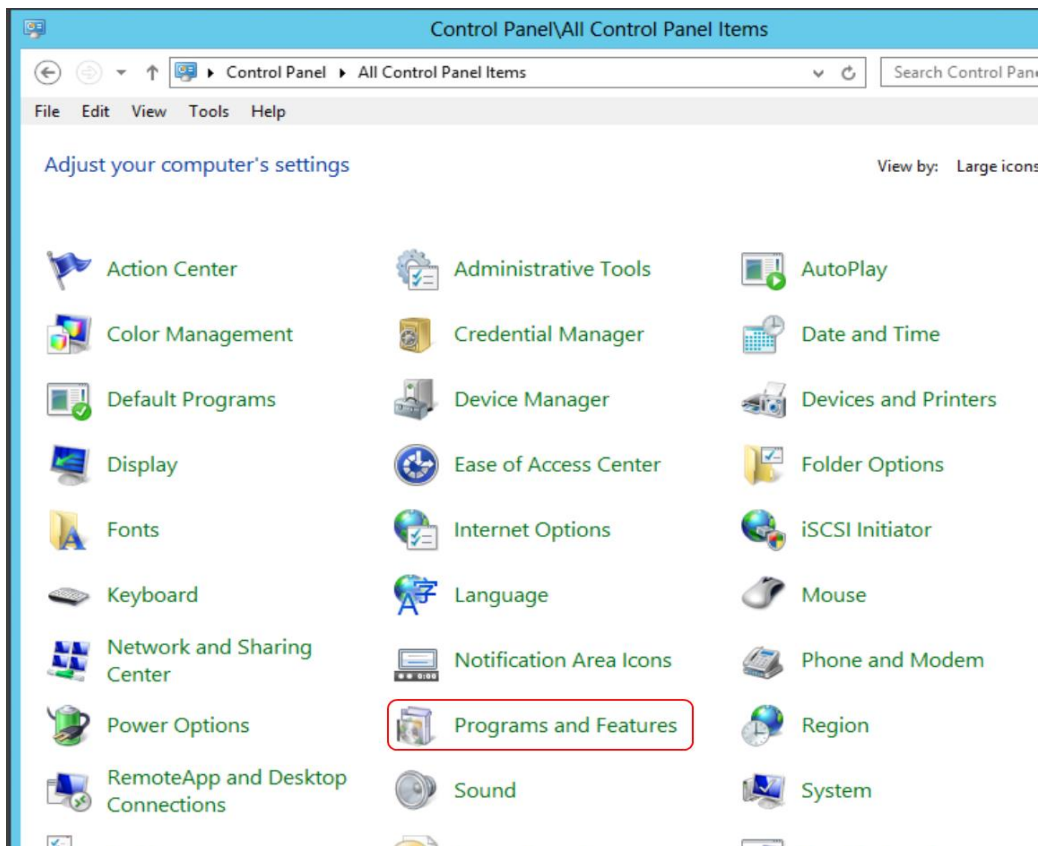

Figure 2-6 “Programs and Features” in Control Panel

Chapter 3 Acquire View, Capture Series Images

This chapter explains how to use Acquire View in *HiBestViewer* to take a series of images through shooting the observed object and store these images. Takes “Python High-Speed Camera” PCE-HSC 1660 for example.

1 Install High-Speed Camera REG/J UE'3882

- 1.1 Use qualified USB 3.0 cable (the length should be shorter than (three meters), directly connect “High-Speed Camera” to USB 3.0 port of PC.
If the distance between PC and “High-Speed Camera” PCE-HSC 1660 is more than three meters, user has to use USB 3.0 hub with external input power to connect USB 3.0 ports between PC to “High-Speed Camera” PCE-HSC 1660.
- 1.2 When PC connects to “High-Speed Camera” PCE-HSC 1660 via USB cable, Windows will automatically recognize “High-Speed Camera” PCE-HSC 1660. If successful, Windows will install drivers for “High-Speed Camera” PCE-HSC 1660.
- 1.3 If Windows cannot recognize “High-Speed Camera” PCE-HSC 1660, user has to install drivers manually for “High-Speed Camera” PCE-HSC 1660. Also, “driver setup program” is attached to “High-Speed Camera” PCE-HSC 1660 products.

2 Start up *HiBestViewer*

- 2.1 Double click “*HiBestViewer* shortcut” to start up *HiBestViewer*.
The default user interface is Acquire View; therefore, user will see Acquire View at the beginning.
- 2.2 If the driver has been installed and at least one “High-Speed Camera” PCE-HSC 1660 directly connects to PC, then user will see Figure 3-1. It is shown that *HiBestViewer* detects “High-Speed Camera” and automatically selects it as “controlled target”. Therefore, in Figure 3-1, Acquire View shows the sensor type of “High-Speed Camera” PCE-HSC 1660 and provides options for manipulating and also user may preview the result.

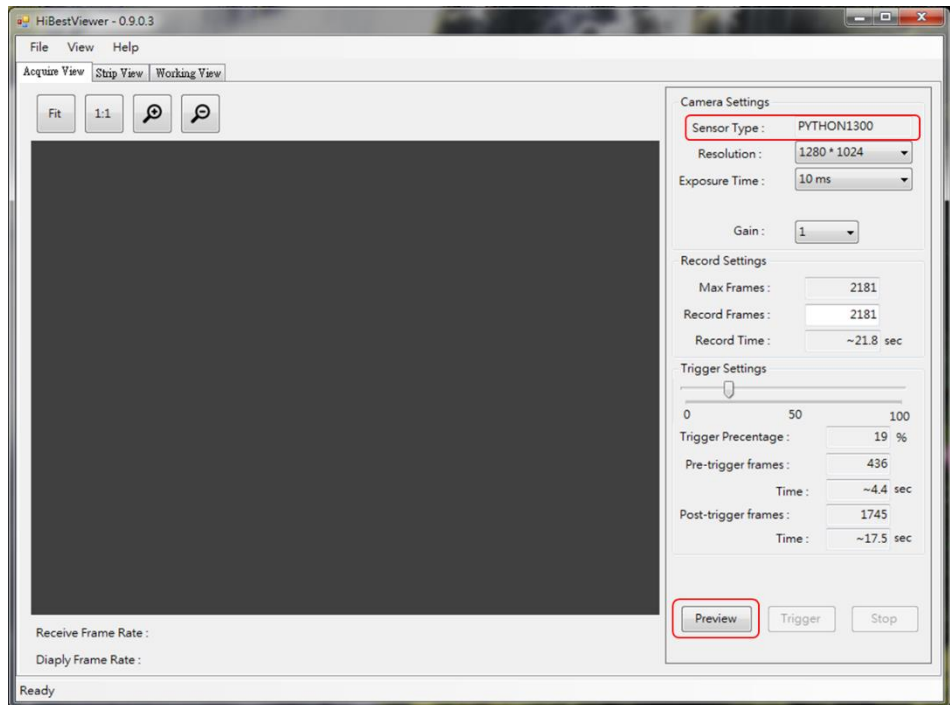

Figure 3-1 Successfully detect “High-Speed Camera” PCE-HSC 1660

2.3 On the contrary, if fail to detect camera, then user will see Figure 3-2, all the information are blank. It means that all options are disabled. Preview function cannot work, either.

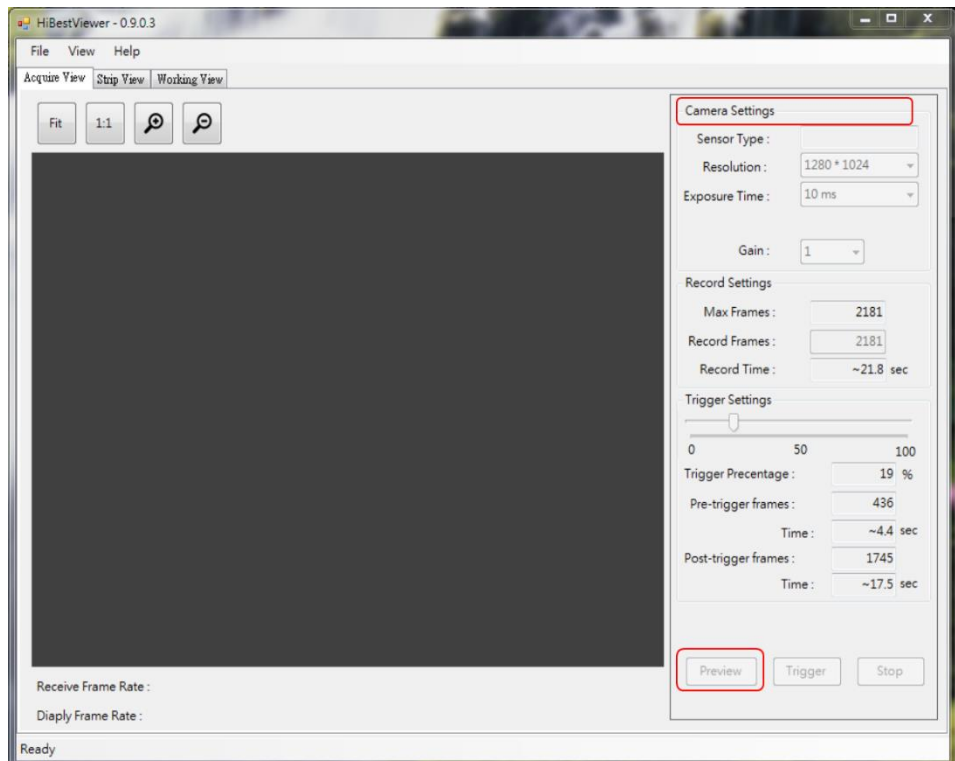

Figure 3-2 Fail to detect “High-Speed Camera” PCE-HSC 1660

2.4 *HiBestViewer* can automatically detect “if High-Speed Camera is connected”. Therefore, if user connects “High-Speed Camera” after *HiBestViewer* running, then it will take approximately 10 ~ 20 seconds to be well aware of “High-Speed Camera”. It takes times since Windows needs to enforce all USB standard procedures for a new connected USB device. If successful, user interface will be restored to Figure 3-1.

3 Acquire View Function Description

If “High-Speed Camera” successfully connects to PC, then available functions are as below:

3.1 Camera Settings: *HiBestViewer* provides user interface to control three basic parameters setting (See Figure 3-3).

3.1.1 Camera Resolution Setting: The resolution supported by camera is limited, so user is only allowed to select appropriate resolution via the context menu.

3.1.2 Camera Exposure Time Setting: The exposure time supported by camera is limited, so user is only allowed to select appropriate exposure time via the context menu.

3.1.3 Camera Gain Value Setting: The gain value supported by camera is limited, so user is only allowed to select appropriate gain value via the context menu.

In addition, when Preview is in progress, any setting options are disabled.

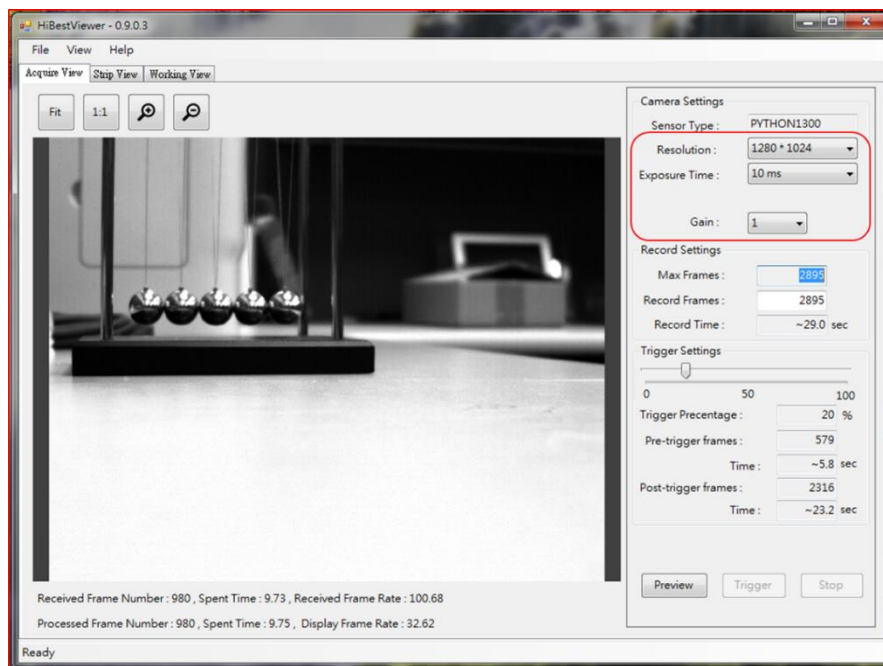

Figure 3-3 Camera basic parameter settings

- 3.2 Record Settings: See Figure 3-4
- 3.2.1 Max Frame: It shows that the maximum of images can be stored. It is an information field and cannot be revised. Its value depends on “current total available memory capacity” and “memory capacity for one image”. Therefore, this value will change if total available memory capacity is changed. If user needs to store more images, then it is recommended to close unnecessary applications and refresh Acquire View (e.g.: switch to Strip View or Working View and then switch back to Acquire View). Besides, if PC memory capacity is actually increased, it also works.
 - 3.2.2 Record Frames: Set up the number of images want to be stored. User can set up the value based on requirements, but the maximum cannot be over the former field (Max Frames), and the minimum cannot be less than or equal to 0.
 - 3.2.3 Record Time: It is an estimated time to complete the record job. The estimation is based on the former field (Record Frames) and frame rate of capturing image. It cannot be revised (unit: second).
 - 3.2.4 Trigger Settings: Set the trigger position. 0% ~ 100% is as setting range, and its definition is as below:
 - 3.2.4.1 When setting value is 100%: It means all of series images that have been captured and kept in the memory will be stored when the trigger occurs. In other words, when the trigger occurs, just store what user has got before trigger, and it is not necessary to capture any new images.
 - 3.2.4.2 Setting value is 0%: It means when the trigger occurs, the system will start to capture images from zero. And it will keep capturing images and put captured images into memory until reach the number that is specified in Record Frames field or user stops the operation. In other words, when the trigger occurs, the system will drop all images that have captured before trigger. And then restart to capture images until reach the goal or user stops the operation.

3.2.4.3 Setting value is $n\%$ and $n > 0$, $n < 100$. It means that before trigger, $n\%$ images already are kept in the memory. Therefore, the system will keep capturing images and put captured images into memory until reach Record Frames value * $(100\% - n\%)$ or user forces to stop the operation. And then store all of series images from the memory.

User can use mouse to drag Trigger Settings Bar to set up trigger position. The detailed information is displayed on the bottom of Trigger Settings Bar, and cannot be revised (See Figure 3-5).

3.2.4.4 Trigger Percentage: Display setting value after dragging Trigger Settings Bar, and the range is $0\% \sim 100\%$.

3.2.4.5 Pre-trigger frames: Total number of images that has been kept in the memory before trigger.

3.2.4.6 Pre-trigger Time: The estimated record time before trigger.

3.2.4.7 Post-trigger frame: Total number of images that needs to be captured after trigger.

3.2.4.8 Time (Post-trigger Time): The estimated record time after trigger.

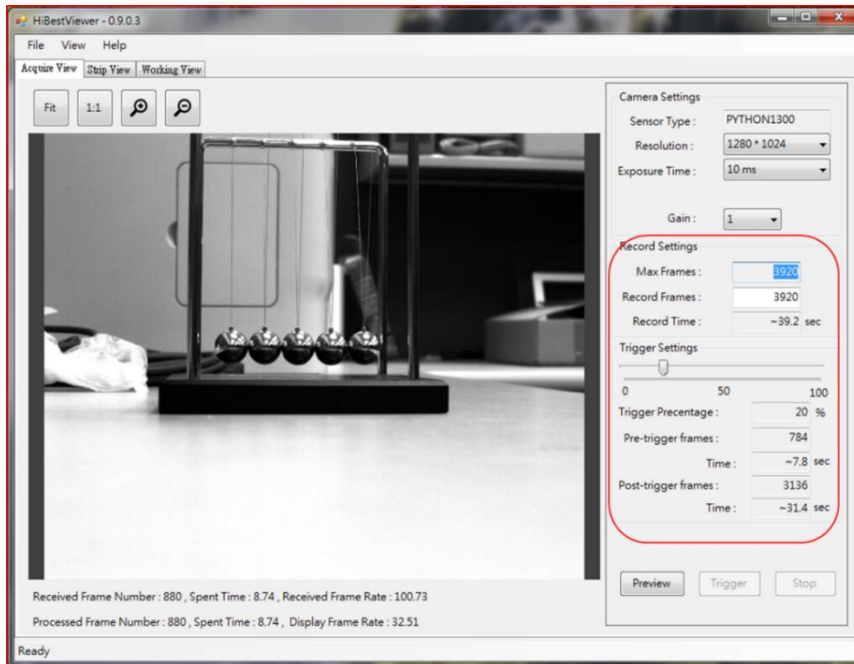

Figure 3-4 Record Settings section

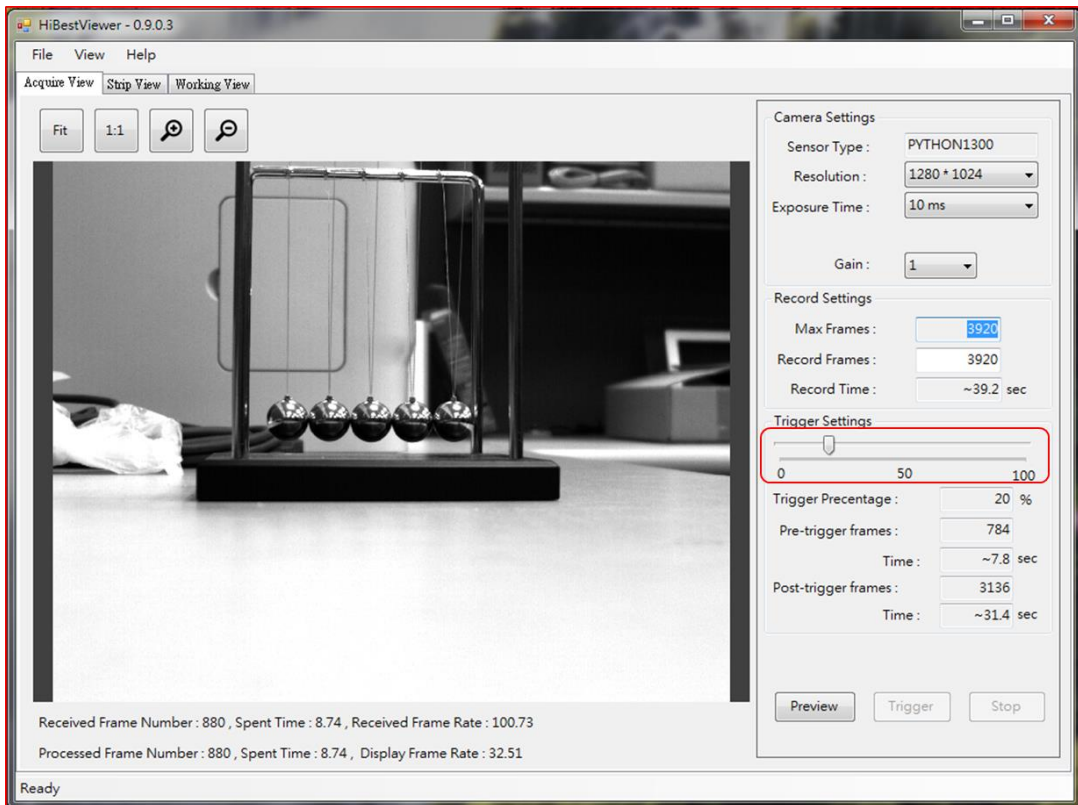

Figure 3-5 Trigger Settings Bar section

- 3.3 Preview: Click “Preview button” to start, a series of images will be sent back to PC through USB and displayed in the Preview Window. Also, “Preview Progressing Information” on the bottom of Preview Window shows the received number of image frames, passed time, (Unit is second, and accurate to 2 decimal places) and frame rate (fps) Note: Received Frame Number is the actual number of images sent back to PC from camera; Processed Frame Number is the number of images processed by application. These two values should be the same under the normal condition (See Figure 3-6).

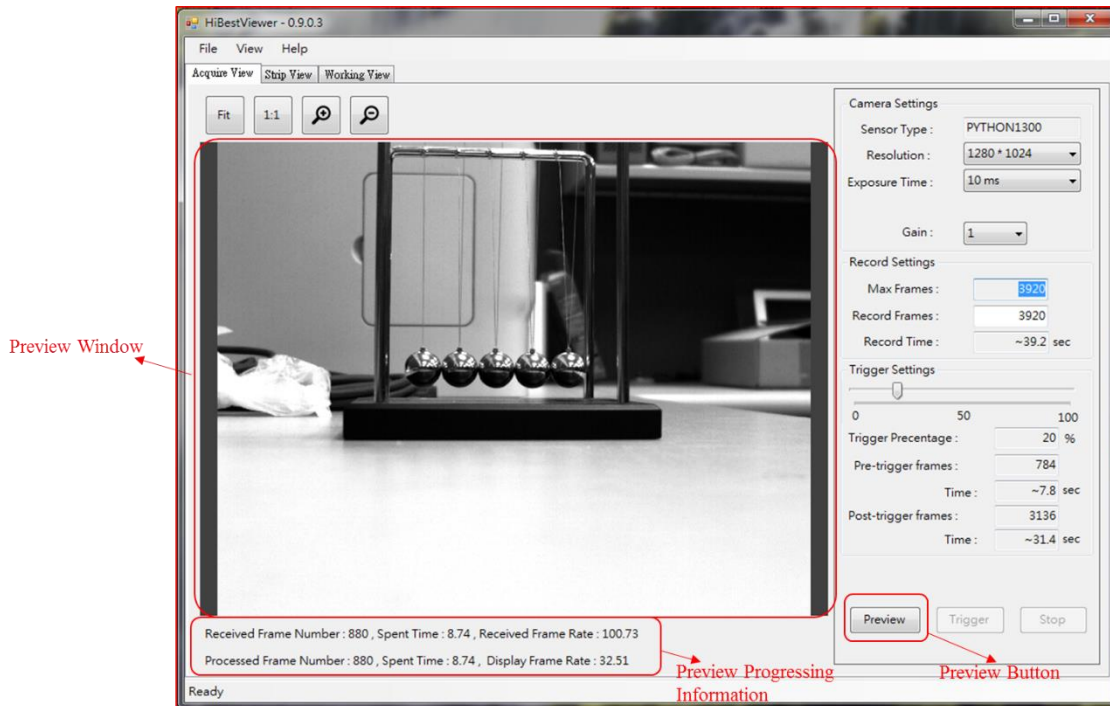

Figure 3-6 Preview Window

3.4 Adjust the display of images in Preview Window: User can adjust the way of images displayed in Preview Window. Acquire View currently supports two display modes:

3.4.1 “Fit”: Fit to Window, based on the size for Preview Window, automatically be adjusted by the program.

3.4.2 “1:1”: Based on the actual size to display. Because the image size is not equal to the size of Preview Window, user may only view the part of image.

Besides, user can use mouse to zoom in/out by clicking the corresponding button (See Figure 3-7).

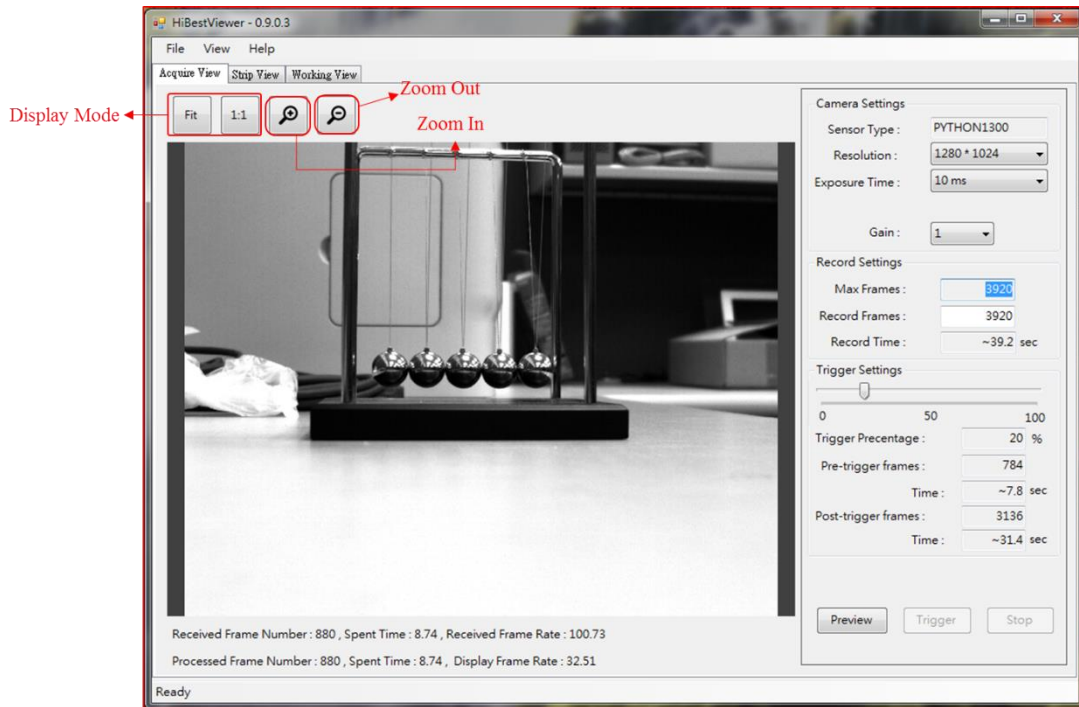
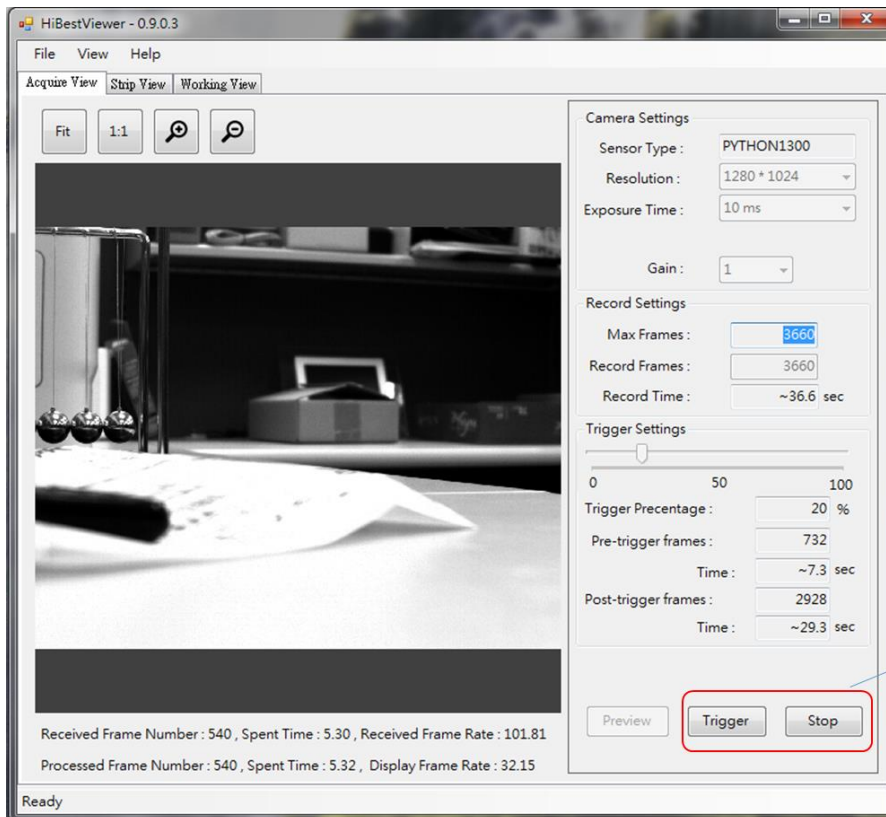

Figure 3-7 Display Mode and Zoom In / Zoon Out

- 3.5 Stop “Preview” and “Store a series of images”: If user starts Preview, “Stop button” will be enabled (See Figure 3-8).
- 3.5.1 Stop Preview: Once click “Stop button”, Preview will be stopped immediately, and show the message, “Stop grab image”. That is, “Preview button” is enabled while Trigger and “Stop button” are disabled (See Figure 3-9).
- 3.5.2 Stop “Preview” and “Store a series of images”: Click “Stop button”, user also already triggers, and the system will cancel the stored images (See Figure 3-10).



Under previewing, The "Trigger" and "Stop" button are enabled.

Figure 3-8 "Trigger and Stop Button" in the process of Previewing

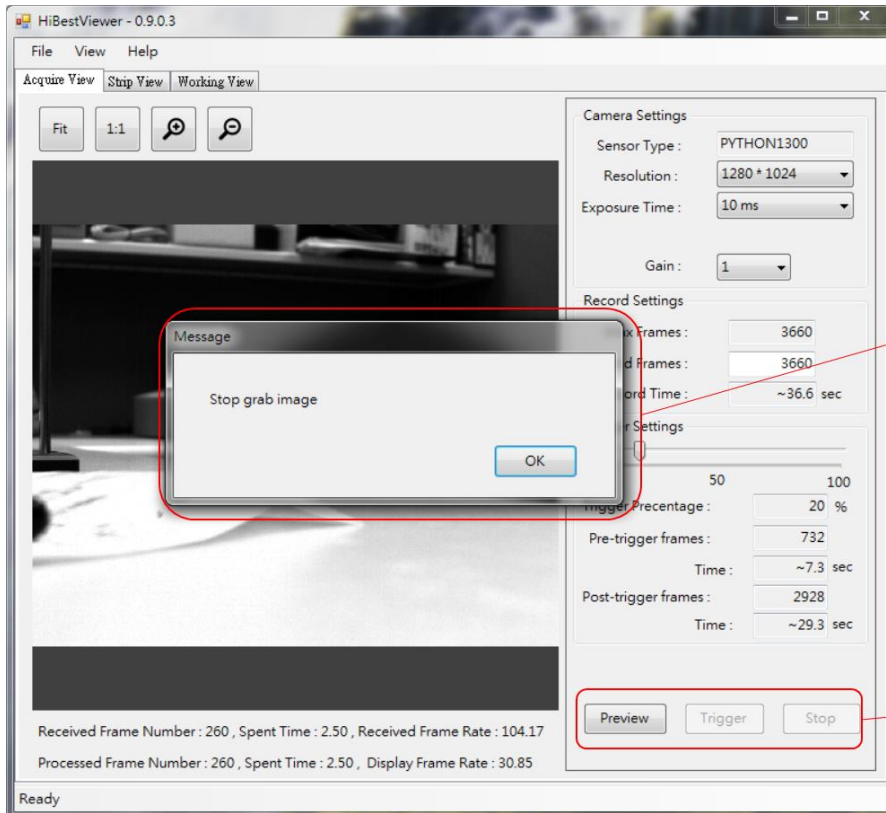

Prompt Message : Preview had been stopped

"Preview" button had been re-enabled, but "Trigger" and "Stop" button had been disabled.

Figure 3-9 Click "Stop Button" to Stop Preview

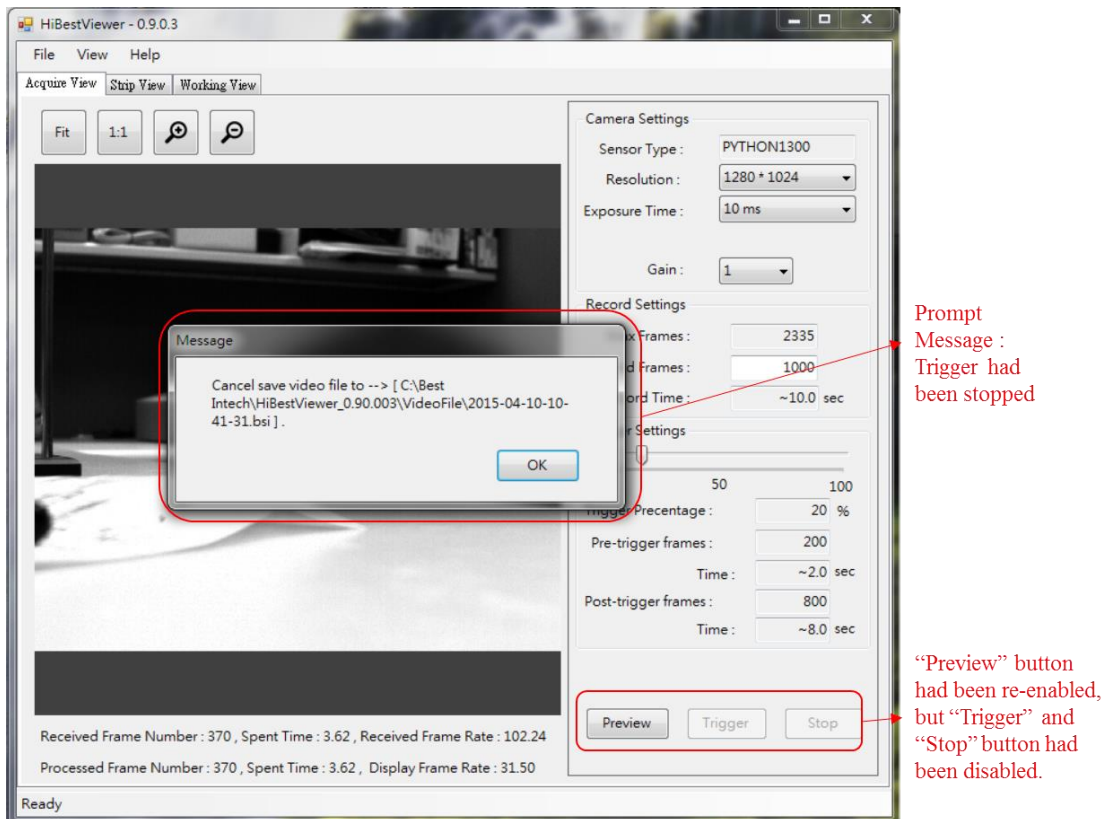

Figure 3-10 Click “Stop Button” to stop Preview and Trigger

- 3.6 Trigger: If user starts Preview, (See Figure 3-8), user can click “Trigger button” any time or use “external triggering signal” to store a series of images. Once being triggered, the description is as below:
- 3.6.1 Follow the trigger position to store a series of images in the memory (Please refer to 3.2.4 Trigger Settings for the detailed description).
 - 3.6.2 If user clicks “Stop button” before a series of images are completely stored, the system will cancel storing a series of images (Please refer to 3.5.2 for the description).
 - 3.6.3 In the process of storing serial images, user interface will show the progress status. Also, “Trigger button” cannot be enabled (See Figure 3-11).
 - 3.6.4 If a series of images is completely stored, the system will automatically stop Preview, and user interface will show the message about the path and filename of serial stored images (See Figure 3-12). In addition, when user clicks “OK” to close the message, the system will automatically switch to Strip View.

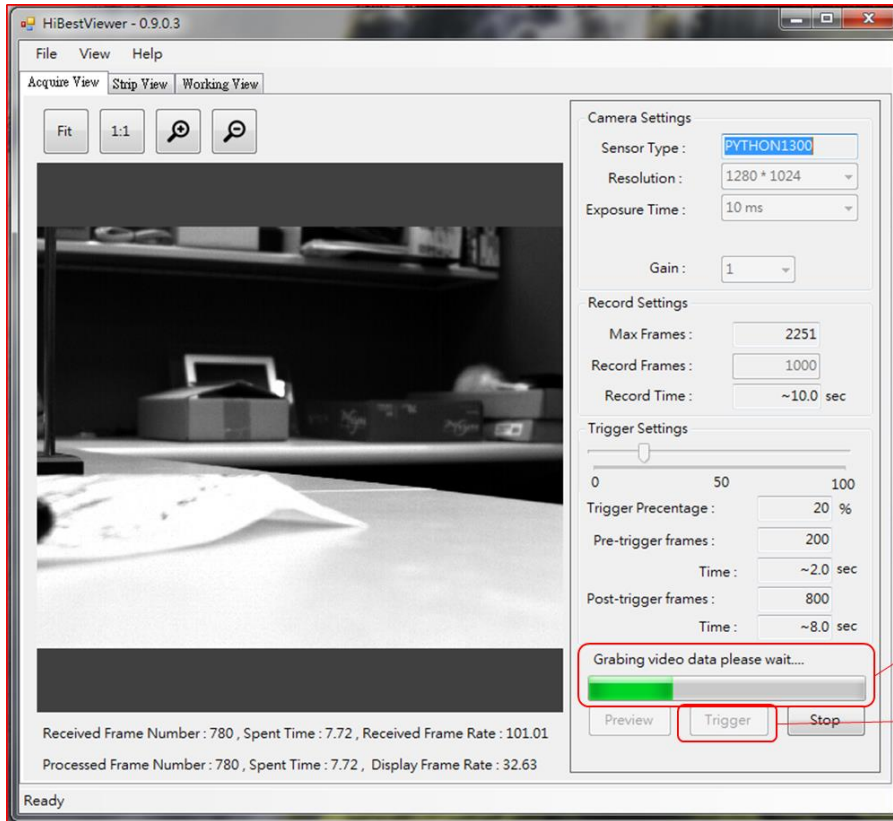

Figure 3-11 User Interface in the process of Trigger

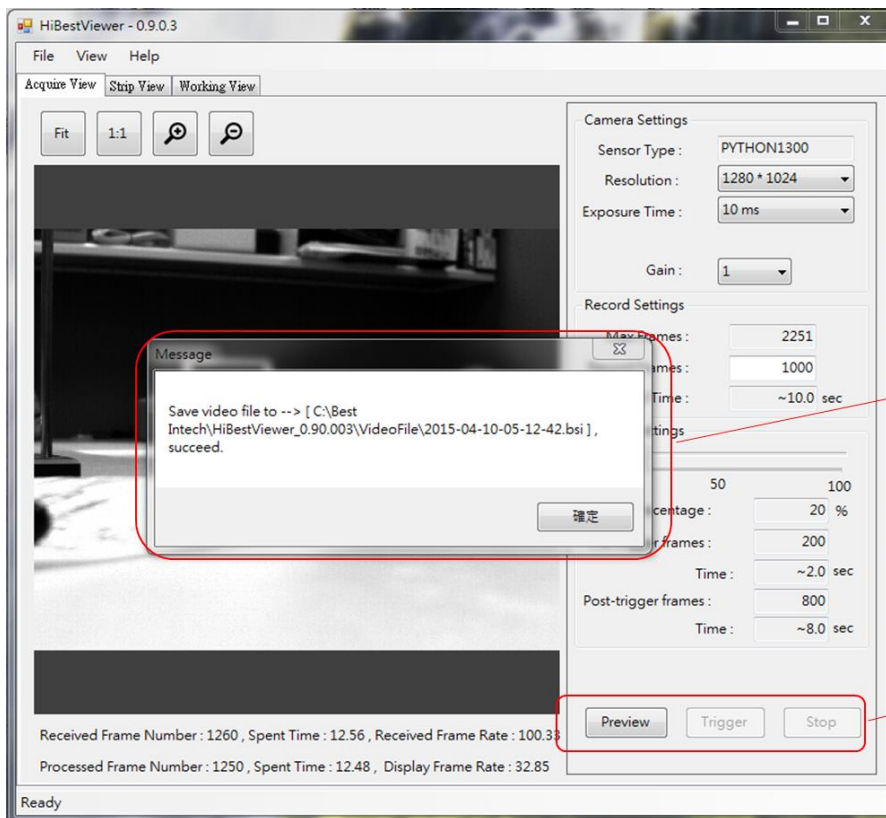

Figure 3-12 User Interface when complete Trigger process

Chapter 4 Strip View, Browse and View Images

This chapter explains how to use Strip View in *HiBestViewer* to browse and view a series of stored images. Besides, user can select a range of data to set up as A-B Play range.

1 How to switch to Strip View

Three ways to switch to Strip View:

1.1 Use mouse to select Strip View on user interface (See Figure 4-1).

Attention: If there is no “a series of stored image”, Strip View will be blank. Besides, Strip View supports to open only one serial image.

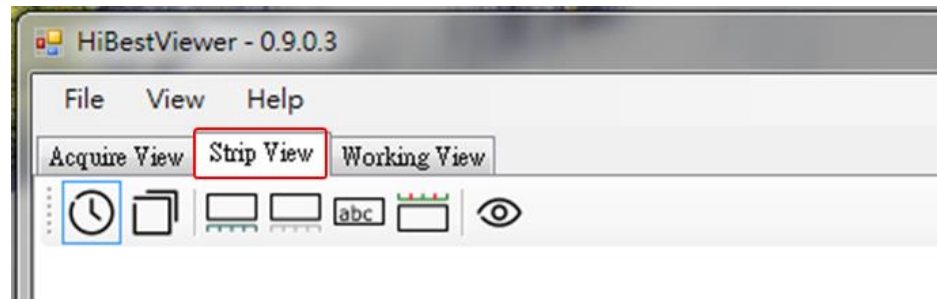

Figure 4-1 Select Strip View Tab Control

1.2 After Acquire View triggers, a series of images will be stored, and the system will automatically switch to Strip View (Please refer to 3.6 in Chapter 3 for detailed description).

1.3 User opens one stored series image before, procedure is as below:

1.3.1 Use mouse to select “File→ Open” on Menu Bar (See Figure 4-2).

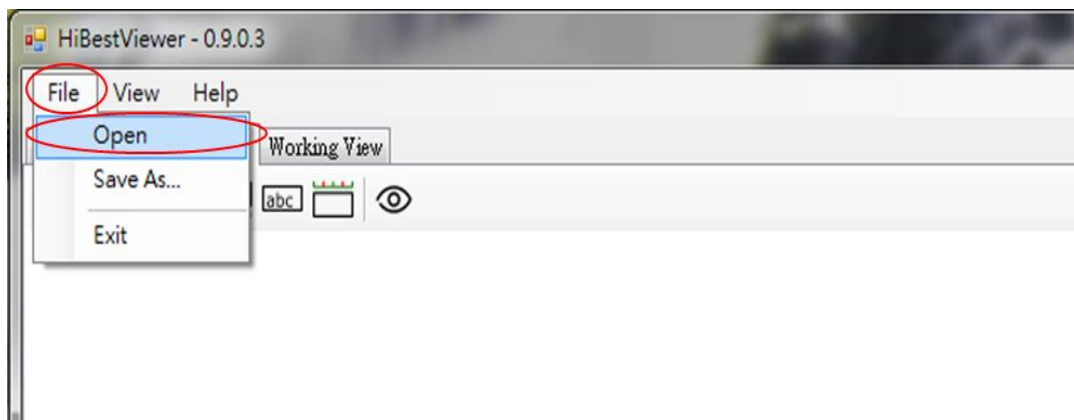

Figure 4-2 Open a series of stored image

1.3.2 The system will open a “Windows API” (See Figure 4-3), and user can select the file to open. If user opens the file successfully, (File format should be fit in with the defined format by *HiBestViewer*) the system will automatically switch to Strip View.

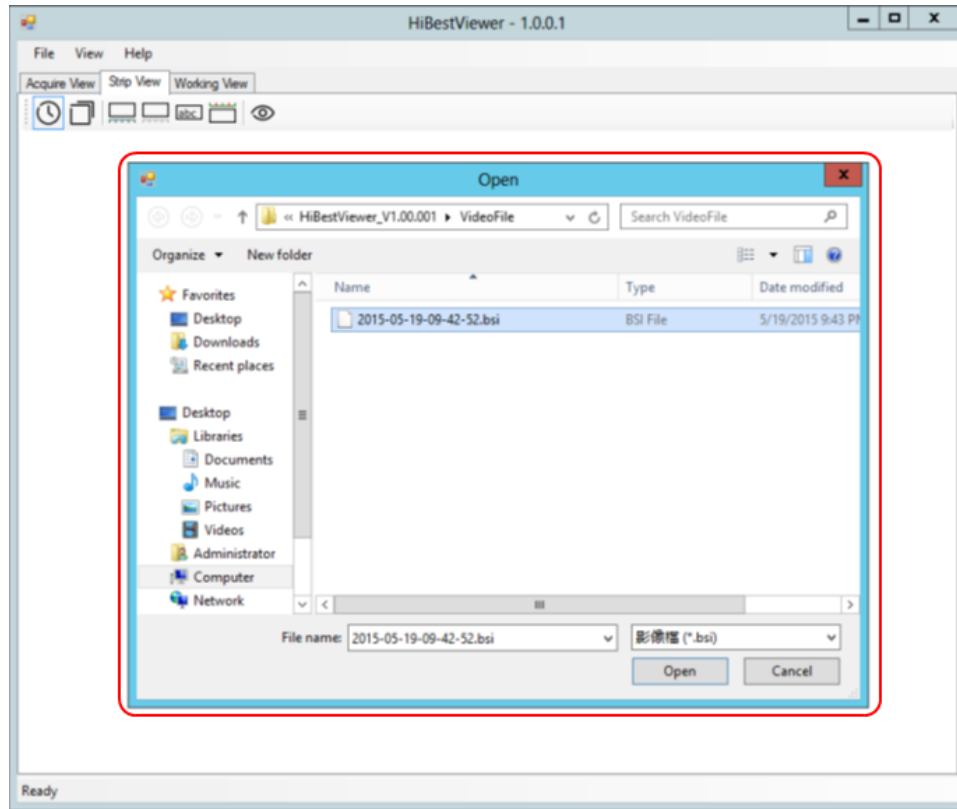

Figure 4-3 Browse and select the file

2 Strip View Static Information

If user successfully opens one serial image, six static information will be displayed on user interface (See Figure 4-4).

2.1 Full path name of the file.

2.2 A series of images attribute data:

2.2.1 Length: Take Figure 4-4 for example, the total number of images is 1000.

2.2.2 Frame Rate: Take Figure 4-4 for example, the Frame Rate is 99 fps.

2.2.3 Image Size: Take Figure 4-4 for example, the image size is 1280x1024 pixels.

2.3 A series of image thumbnails helps user to browse (See Figure 4-4).

2.4 Bookmark makers: Marker is a brown square, on the right corner

of image, for indicating the image is signed.

2.5 Frame number is corresponded to each image thumbnail on the left corner (See Figure 4-4). The sorting rule of frame number is as below:

2.5.1 The image frame number is 0 at the trigger position.

2.5.2 Frame number, a series of images before trigger, is negative. Decrease one backward sequentially.

2.5.3 Frame number, a series of images after trigger, is positive. Increase one forward sequentially.

2.6 The relative time of capturing images is corresponded to each image thumbnail on the left corner of image, on the bottom of frame number (Time unit is second and accurate to the fourth decimal place). The sorting rule of relative time is as below (See Figure 4-4):

2.6.1 The image relative time is 0 at the trigger position.

2.6.2 The relative time, a series of images before trigger, is negative. Decrease sequentially.

2.6.3 The relative time, a series of images after trigger, is positive. Increase sequentially.

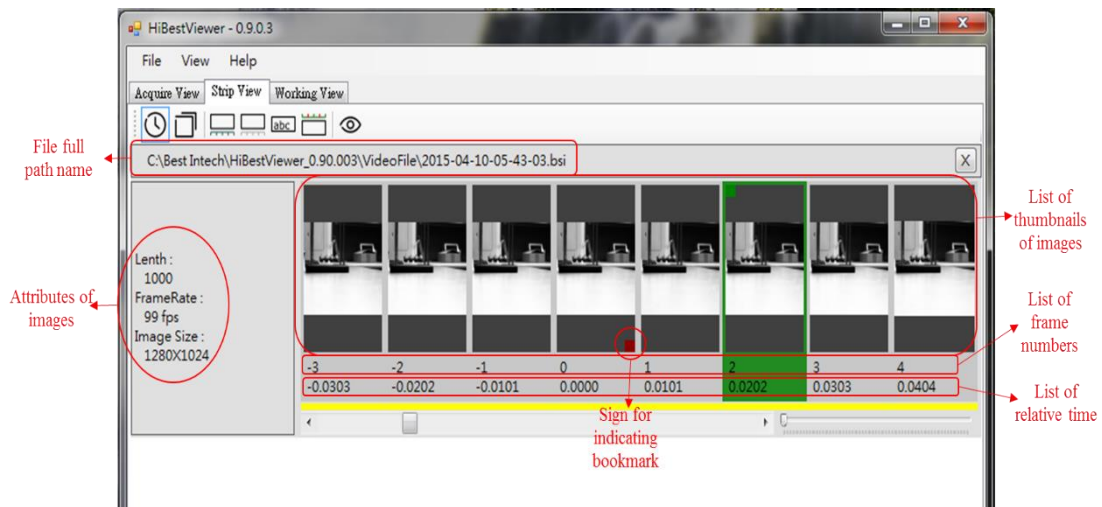

Figure 4-4 Strip View Static Information

3 Strip ViewAuxiliary

In addition to static information, Strip View provides a variety of auxiliary functions, including two parts. The first part: Seven icons on Icon Bar, operates seven view functions. The second part: The function of Scroll Bar and Zoom In/Zoom Out Bar (See Figure 4-5).

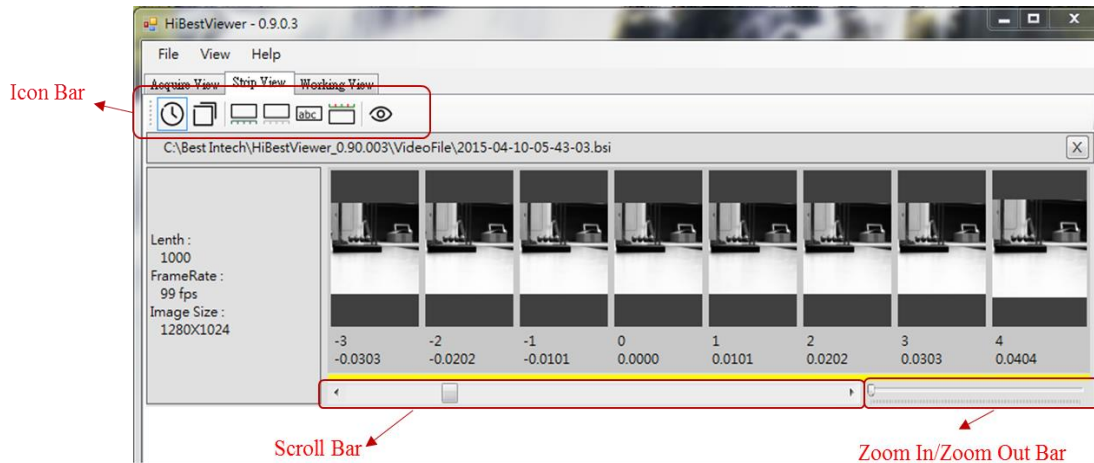

Figure 4-5 Strip View Auxiliary

If want to operate the auxiliary function on Icon Bar, user can use mouse to click the corresponding icon (See Figure 4-6).

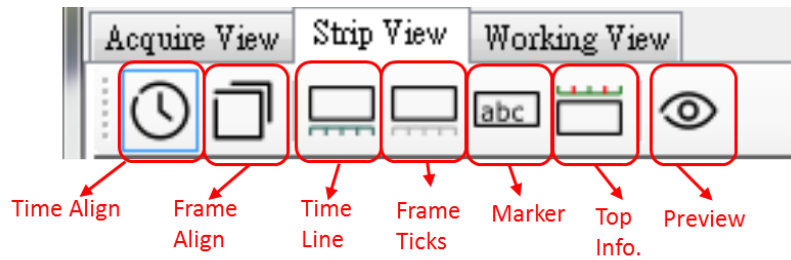

Figure 4-6 Icon Bar View Auxiliary

Auxiliary functions on Icon Bar are as follows:

- 3.1 Frame Ticks: The fourth icon is counted from the left. Use mouse to click this icon to open or close Frame Count Meter. When Frame Count Meter is opened, it will be displayed on the bottom of relative time. Frame Ticks icon will be framed by blue lines. User can use mouse to click Frame Ticks icon to switch. Besides, on the bottom of relative time, there is a list of yellow rectangles aligned left to correspond to the above image thumbnails. User can easily view the yellow rectangles over Frame Count Meter, and realize the interval and position among image thumbnails (See Figure 4-7).

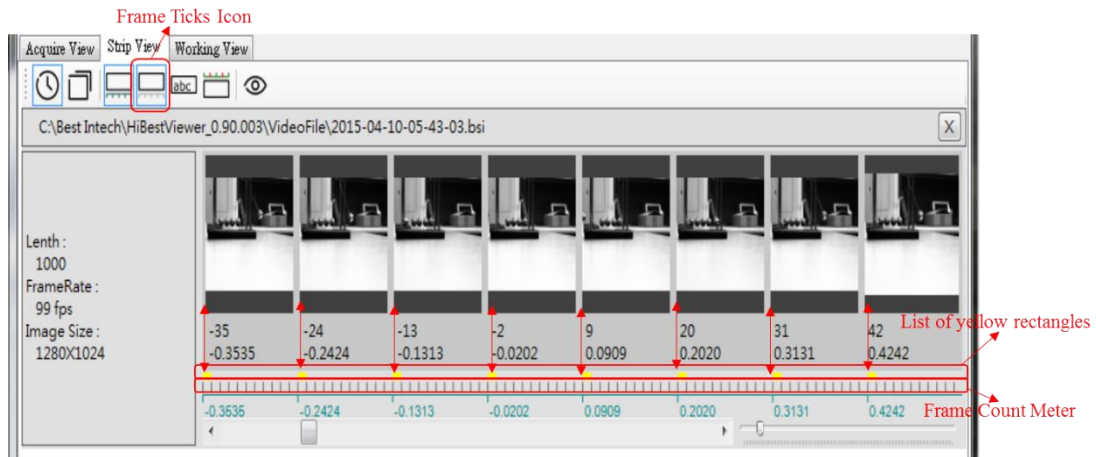

Figure 4-7 Frame Ticks

3.2 Time Line: The third icon is counted from the left. Use mouse to click this icon to open or close Time Line. When Time Line is opened, it will show Time Line over the Scroll Bar, and Time Line icon will be framed by blue lines (See Figure 4-8).

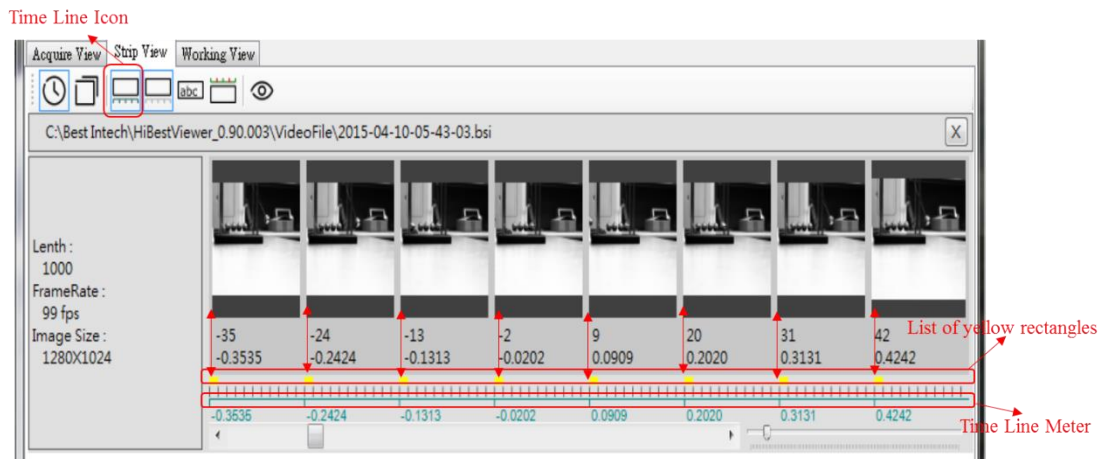

Figure 4-8 Time Line

3.3 Time Align and Frame Align: The first and second icon is respectively counted from the left. These two icons are for switching two units of Time Line. The first unit is time. The second unit is frame number. However, some restrictions are as below:

3.3.1 Only when Time Line is opened will it show the unit of Time Line.

3.3.2 Time Align and Frame Align cannot be displayed at the same time.

User can switch unit to relative time (unit is second and accurate to

the fourth decimal place) by selecting Time Align icon (See Figure 4-9). User can also switch unit to frame number by selecting Frame Align icon (See Figure 4-10).

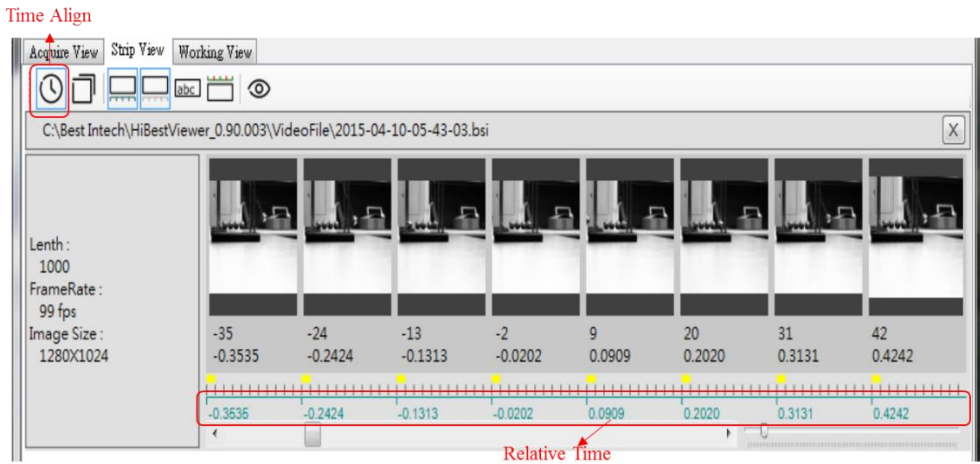

Figure 4-9 Time Align



Figure 4-10 Frame Align

3.4 Marker: The fifth icon is counted from the left. User can use mouse to click Marker icon to switch comment on image thumbnails. When Marker is opened, comment will be displayed on the bottom of images (See Figure 4-11).

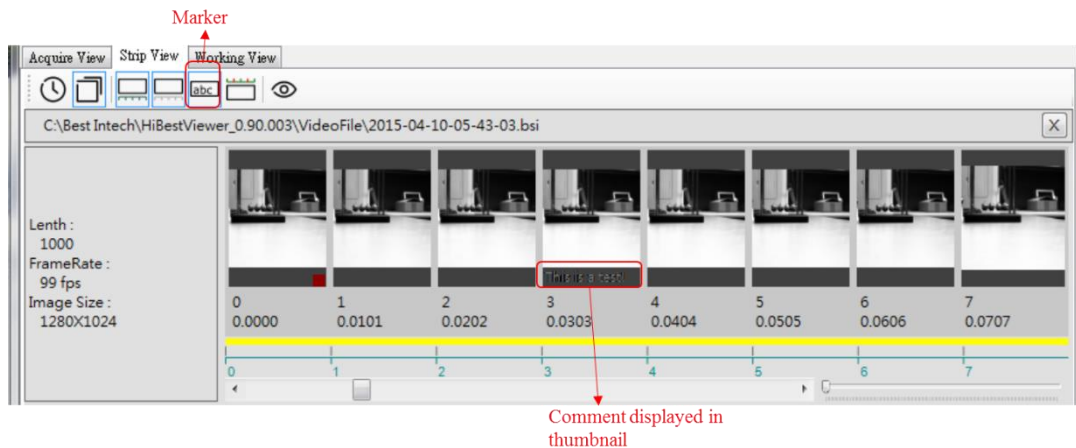

Figure 4-11 Marker

- 3.5 Top Info: The sixth icon is counted from the left. User can use mouse to click Top Info icon to open or close the display of A-B Play range. A-B Play range means that user can specify the range for a series of images. The origin of this range is called A point while the terminal of this range is called B point. The detailed description will be explained in this chapter 5-1. Besides, only one A-B Play range is supported by the system. When opening A-B Play range, there is a red line over the image thumbnails (Take Figure 4-11 for example, Frame Number of A point is -4 while Frame Number of B point is 6).



Figure 4-12 Top Info Display A-B Play Range

- 3.6 Preview: The seventh icon is counted from the left. User can use mouse to click to Preview icon to open or close a single image. User can use mouse to select image thumbnails, which is highlighted to display. When opening Preview, the system will show the image in a new window (See Figure 4-13). Besides, if

user selects a series of image thumbnails (not only select a single image), the system will only show the last selected image when opening Preview instead of showing several images.

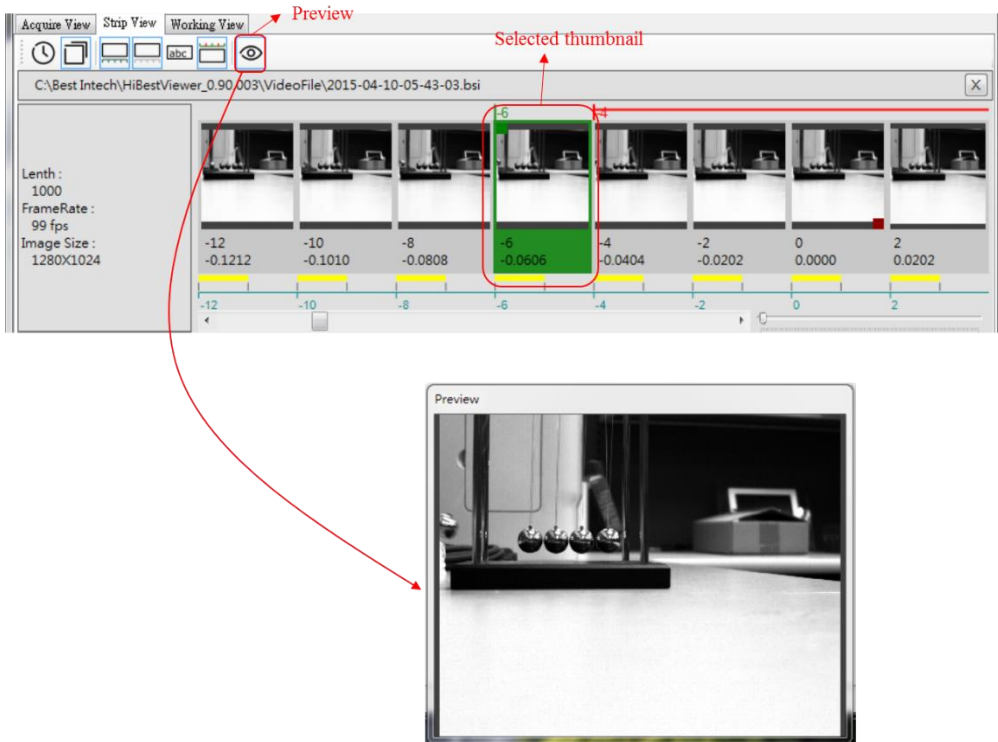

Figure 4-13 Preview Image

3.7 Scroll Bar: Use mouse to click or drag Scroll Bar to scroll series image thumbnails, and user can move the view across all image thumbnails. When scrolling, it can show animation (See Figure 4-14).



Figure 4-14 Scroll Bar

3.8 Zoom In/Zoom Out Bar: Use mouse to click zoom in/out to adjust the view range of a series of image thumbnails (See Figure 4-15).



Figure 4-15 Zoom In/Zoom Out

4 Save a series of images as general-purpose video file

After successfully opening a series of images data, user can save them as general-purpose video file or bitmap files. It can be saved as MPEG2 video file or MP4 video file, supported by the current system. A series of images also can be saved as serial bitmap files (Microsoft bmp file format).

4.1 Two ways to start “Save as User Interface”:

4.1.1 Use mouse to select File → Save As (See Figure 4-16).

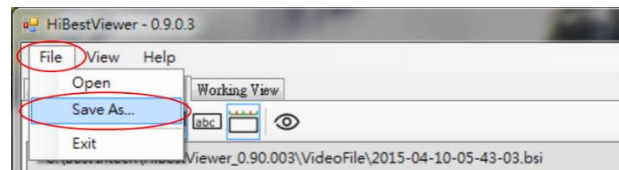

Figure 4-16 “Save as User Interface” from Menu Bar

4.1.2 Within image thumbnails, right click to select Context Menu and then select Save As (See Figure 4-17).

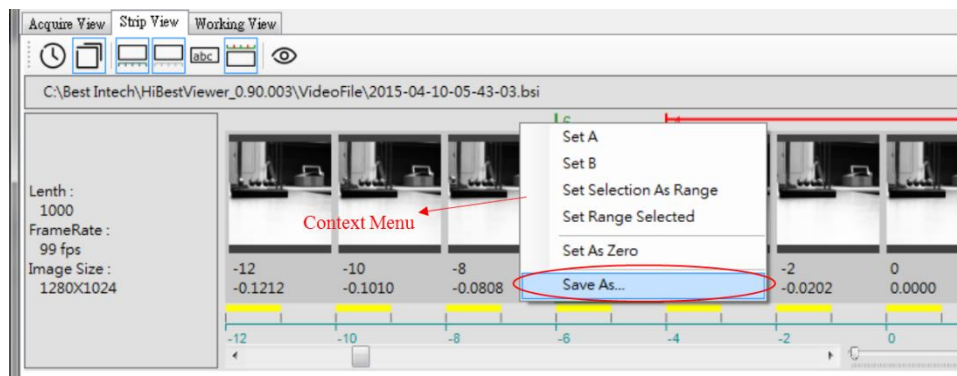

Figure 4-17 “Save as User Interface” from Context Menu

4.2 “Save as User Interface” :

4.2.1 “Save as User Interface” is similar to “Windows Save As User Interface”. Therefore, User can select the path and file name on this interface (See Figure 4-18).

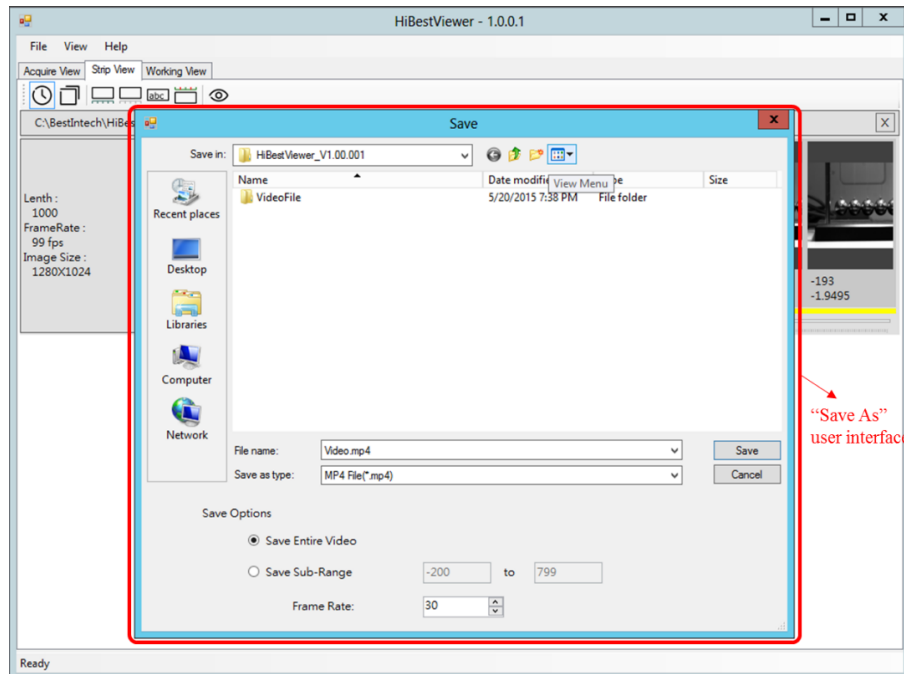

Figure 4-18 “Save As” User Interface

4.2.2 File type: User can select file type on user interface based on requirements. Take Figure 4-19 for example, it is selected as MP4 video file type.

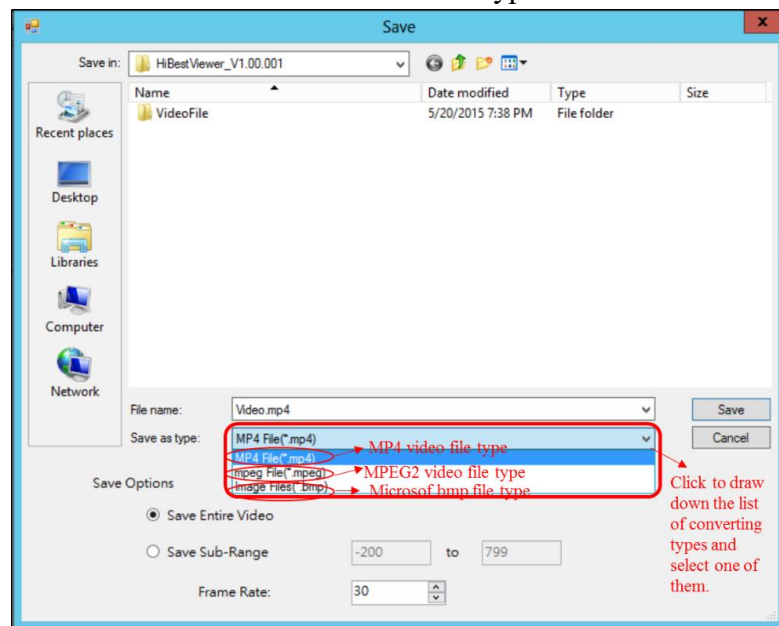

Figure 4-19 Select Save as File Type

- 4.2.3 Select “Save Options” (See Figure 4-20), there are three options described as below:
- 4.2.3.1 Save Entire Video: Select this option if want to convert and save all of series image data as another file type.
 - 4.2.3.2 Save Sub-Range: Select this option if want to convert and save part of a series of images as another file type. Also, user has to specify the start and the end of frame number.
 - 4.2.3.3 Select this option to specify frame rate, but it is valid only when the file is save as MP4 video file type or MPEG2 video file type.

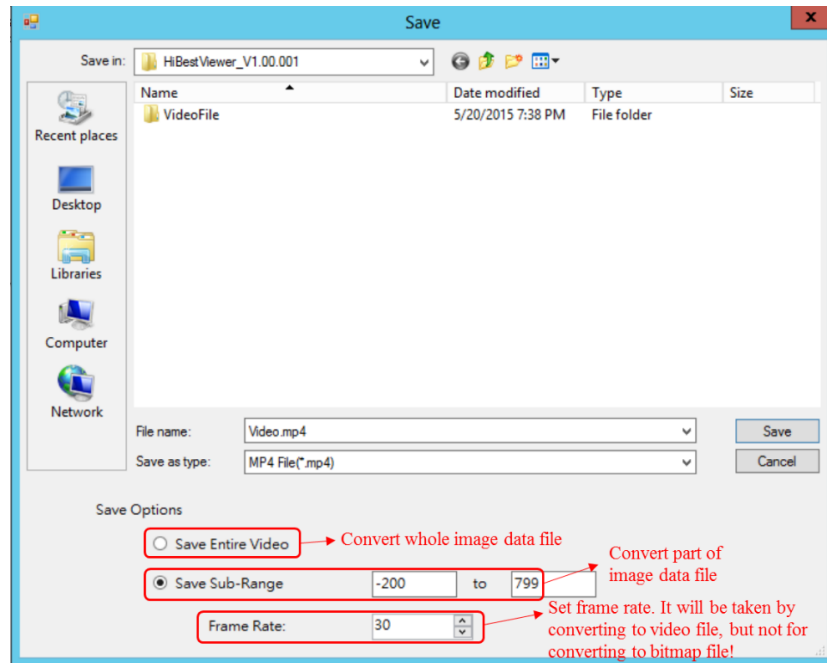

Figure 4-20 Save Options

5 Context Menu Function within Image Thumbnails

Right click mouse to show Context Menu within image thumbnails (See Figure 4-21).



Figure 4-21 Context Menu

Context Menu functions are described as follows:

- 5.1 Set A and Set B: Set A-B Play range (See Figure 4-22).
 - 5.1.1 The default A-B Play range includes all images. In other words, A point is the first image frame while B point is the last image frame.
 - 5.1.2 Select “Set A” in Context Menu, and the system will set the selected image as A point (the start) of A-B Play range.
 - 5.1.3 Select “Set B” in Context Menu, and the system will set the selected image as B point (the end) of A-B Play range.
 - 5.1.4 Nothing will happen if there is no selected image when setting A point or B point.
 - 5.1.5 On the contrary, if there are more than one selected images when set A point or B point, then the last selected image will be the setting target.

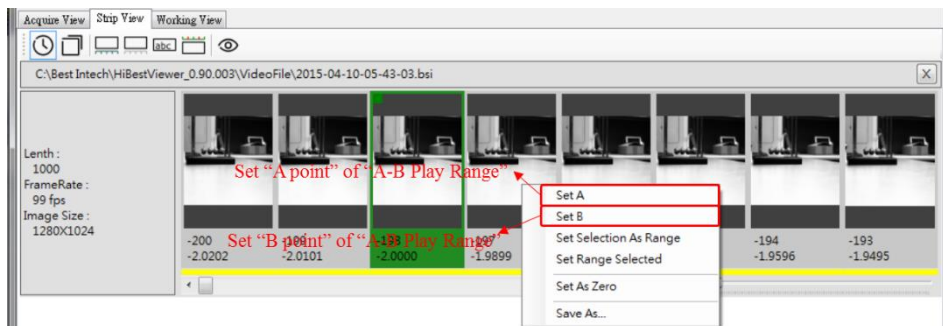

Figure 4-22 Set A-B Play Range

- 5.2 Set Selection As Range: Set “a series of images segment” as A-B Play range (See Figure 4-23).
 - 5.2.1 Select a series of images segment:
 - 5.2.1.1 Use mouse to select a point (the start or end) in a series of image thumbnails segment. Selected image thumbnails will be highlighted.
 - 5.2.1.2 Hold down “Ctrl key” or “Shift key”.
 - 5.2.1.3 Use mouse to select the other point in a series of image thumbnails segment. And all image thumbnails in a series of image thumbnails segment will be highlighted.
 - 5.2.2 After selecting a series of image thumbnails segment, and then select “Set Selection As Range” in Context Menu to set A-B Play range.
 - 5.2.3 Nothing will happen if there is no selected image

thumbnails when clicking “Set Selection As Range”.

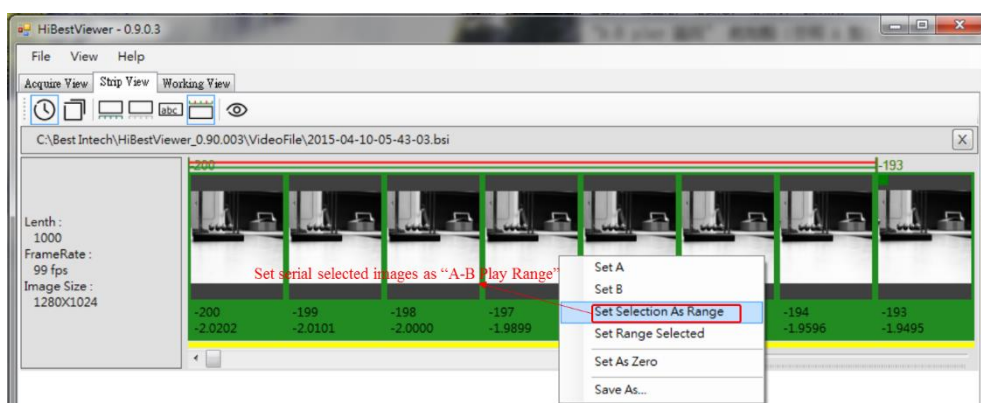

Figure 4-23 Set selected images as A-B Play Range

5.3 Set Range Selected: All image thumbnails are selected in A-B Play range. After clicking this menu item, user will see all image thumbnails highlighted in A-B Play range (See Figure 4-24).

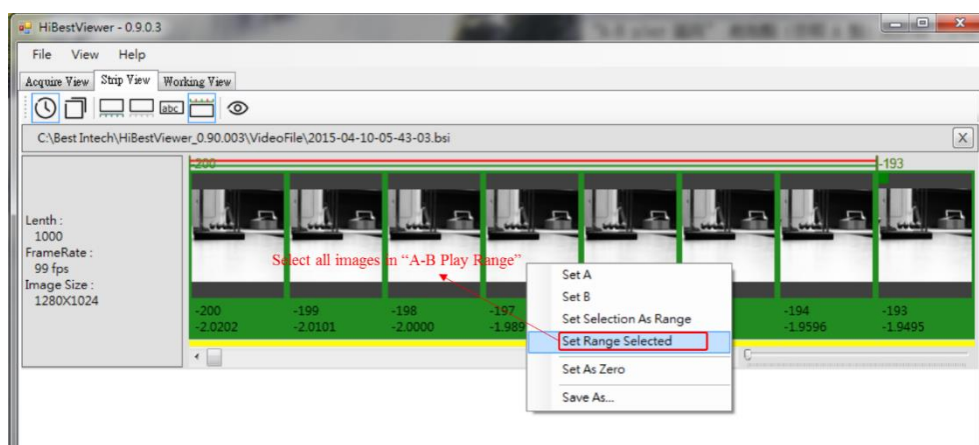

Figure 4-24 Select all images in A-B Play Range

5.4 Set As Zero: Set frame number and relative time of selected image to 0, and the system will revise frame number and relative time of all images based on “sequence correlation”. Take Figure 4-25 for example, the selected frame number is -200 and changes to Frame number 0. However, two exceptions are described as below:

5.4.1 If there is no selected image, then nothing will happen when enforce “Set As Zero”.

5.4.2 On the contrary, if “Set As Zero” is selected, and there are more than one images selected. The system will take the last selected image to be the 0 point.

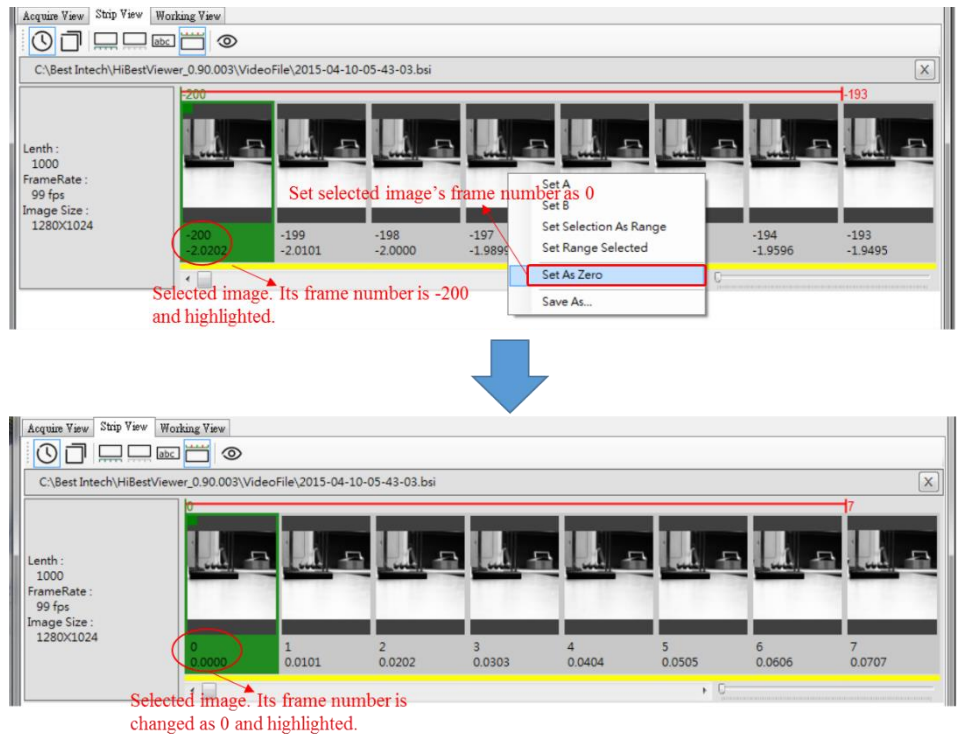

Figure 4-25 Set As Zero

5.5 Save As...: User can save a series of images as general-purpose video file or bitmap files. Please refer to the section 4 in this chapter for the detailed description.

6 Switch from Strip View to Working View

User can switch Strip View to Working View by double clicking within image thumbnails. After switching to Working View, Play Head will move to the image which user double clicks in Strip View.

Chapter 5 Working View, Further Examining and Processing

This chapter explains how to use Working View in *HiBestViewer* to examine and process stored images.

1 How to switch to Working View

Two ways to switch to Working View. It is highly recommended to take “switch from Strip View to Working View” method. Because it is the only method to guarantee the file displayed in Working View that is exactly the same file opened in Strip View.

- 1.1 Use mouse to click Working View tab control on user interface (See Figure 5-1). **Attention: Working View will be blank if user never opens any a series of stored images or switches from Strip View to Working View before.**

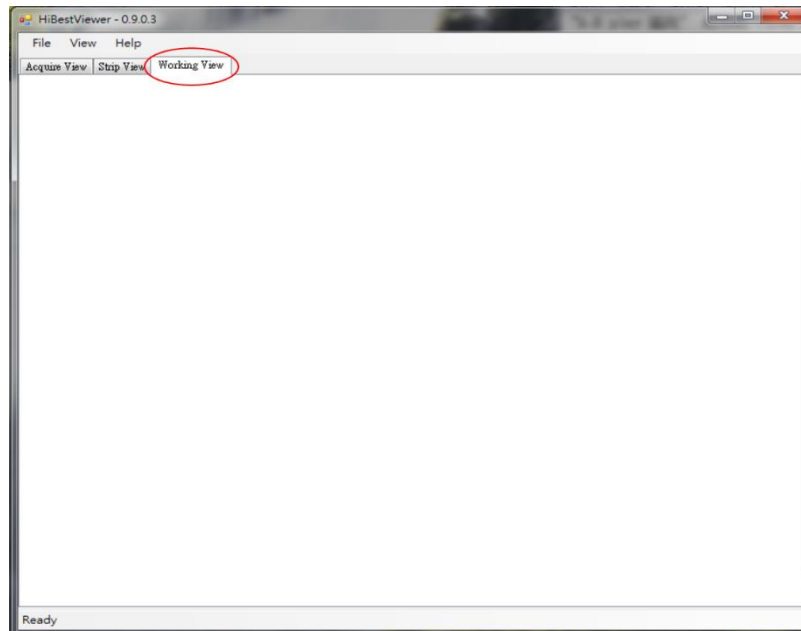

Figure 5-1 Select Working View Tab

- 1.2 Switch from Strip View to Working View: Double click within image thumbnails in Strip View (See Figure 5-2).

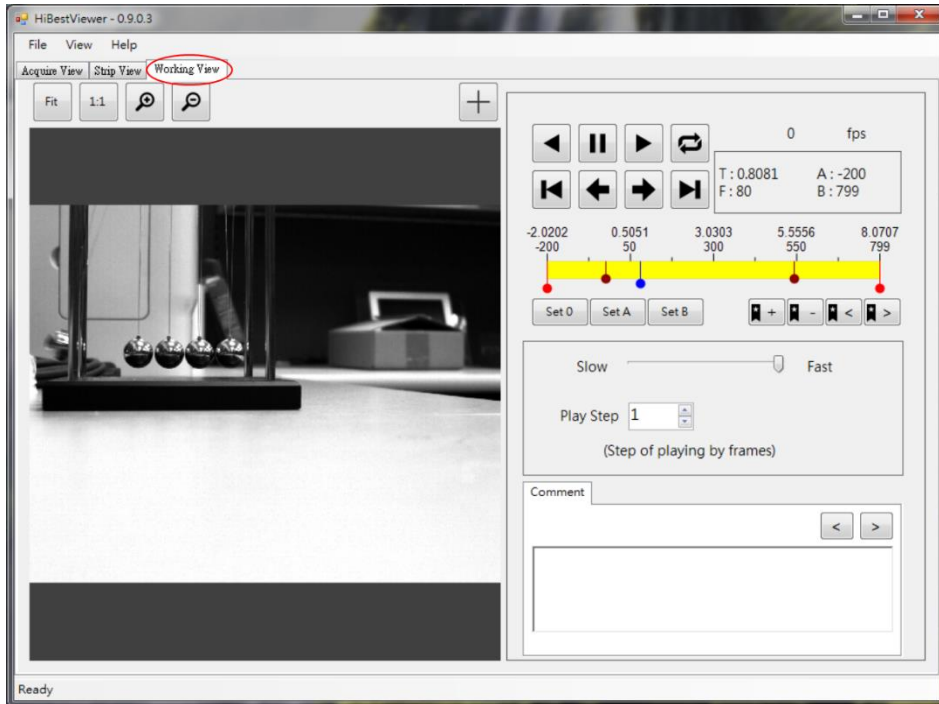

Figure 5-2 Switch from Strip View to Working View

2 Play Control

Play control is classified as five parts: (1) Play Control Buttons (2) Play Status Information (3) Play Progress Bar (4) Play Frame Rate & Play Step Interval (5) Play Display Windows & Display Settings (See Figure 5-3).

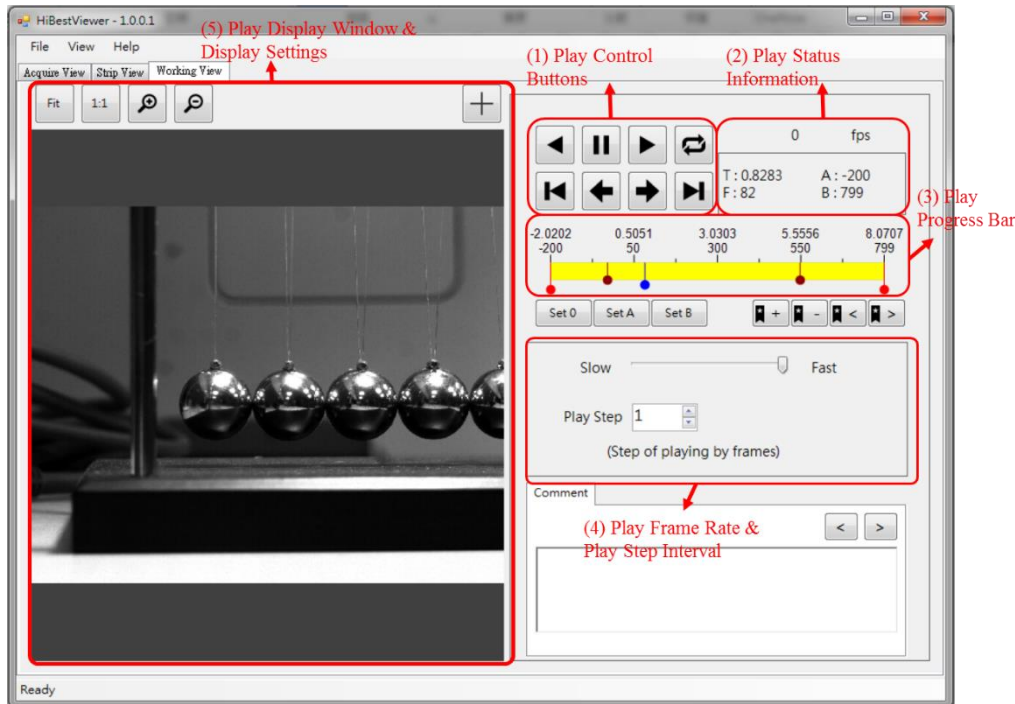





Figure 5-3 Five parts of Play Control



User can use these Play Control buttons for fine tuning play back and display image in order to further examine the image data and correlation among a series of images. Functions of each part are described as follows:

2.1 There are eight Play Control Buttons shown as below:

2.1.1  (Reverse Play Button): Use mouse to click this button to make images display backward sequentially from Play Head position until user click “Stop Play Button” or all images in A-B Play range has just finished playing.

2.1.2  (Stop Play Button): Use mouse to click this button to stop the play. Nothing will happen if there is no play back proceeding.

2.1.3  (Normal Play Button): Use mouse to select this button to make images display forward sequentially from Play Head position until user clicks “Stop Play Button” or all images in A-B Play range has just finished playing.

2.1.4  (Cyclic Play Button): Use mouse to turn on/off cyclic play mode. This button will be highlighted when being turned on, see Figure . When this mode is turned off, the button will restore to the original, see Figure .

Under cyclic play mode, after playing all images, it will replay again automatically.

2.1.5  (Move to A point Button): Use mouse to click this button to make Play Head move to A point in A-B Play range (the start point in A-B Play range).

2.1.6  (Reverse Step Play Button): Use mouse to click this button to make images play only one step backward from Play Head position.

2.1.7  (Normal Step Play Button): Use mouse to click this button to make images play only one step forward from Play Head position.

2.1.8  (Move to B point Button): Use mouse to click this button to make Play Head move to B point in A-B Play range (the end point in A-B Play range).

- 2.2 There are five Play Status Information as follows:
- 2.2.1 Play Speed: The number of images will be displayed per second, see Figure 5-4 (fps → frame per second).
 - 2.2.2 Play Head position: This information is represented by Frame Number and Relative Time. Time unit is second and accurate to the fourth decimal place (See Figure 5-4).
 - 2.2.3 A-B Play Range: This information is for A point and B point as Frame Number (See Figure 5-4).

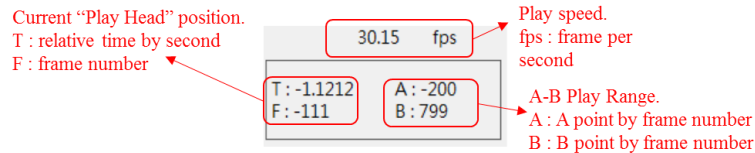

Figure 5-4 Play Status Information

- 2.3 Play Progress Bar: It provides several information, the setting of A-B Play range, and Play Head position:
- 2.3.1 Overview on Play Progress Bar: The length of the progress bar represents amount of all images data. Scales over the progress bar are marked corresponding to Frame Number and Relative Time. The time unit is second and accurate to the fourth decimal place (See Figure 5-5).

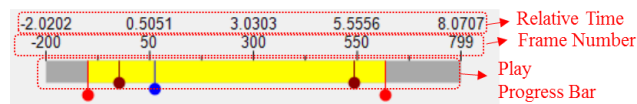





Figure 5-4 Overview on Play Progress Bar

- 2.3.2 Position marker: User will see three kinds of position marker on Play Progress Bar.
 - 2.3.2.1  (Play Head): The current position of Play Head. If want to know Play Head information, user can check Play Status Information (Please refer to 2.2.2 for the description). It will be updated when playing. Besides, all play back functions (such as Reverse Play, Normal Play, Normal Step Play, ...) in Working View may work only if Play Head locates within A-B Play range. If Play Head does not locate within A-B Play range, then all play back

functions will not work. For letting play back functions work, user can adjust A-B Play range or use mouse to click “Move to A Point Button” (or “Move to B Point Button”) to make Play Head move into A-B Play Range.

2.3.2.2  (A-B Play Range): There are two markers on Play Progress Bar. A point located on the left is marked while B point located on the right is marked. A-B Play range on Play Progress Bar is shown as yellow rectangle. If want to know the information about A-B Play range, please check Play Status Information (Refer to 2.2.3 for the description).

If user only sees one marker, it means that A point is the same as B point, resulted in overlapping. User can use mouse to drag the marker to separate them.

2.3.2.3  (Bookmark): User can use Bookmark to mark a position where user want to remember on Play Progress Bar.

2.3.3 Operate the position marker: User can use mouse to drag the marker.

2.3.3.1 Use mouse to drag  (Play Head) to change Play Head position even play back is going, only within A-B Play range.

2.3.3.2 Use mouse to drag  (A-B Play range marker) to change A-B Play range.

2.4 Play Frame Rate & Play Step Interval: User can set Play Frame Rate (frames per second). User can adjust the play interval for every step.

2.4.1 Set Play Speed (frame per second): Use mouse to drag Play Speed Slider, and the speed will be shown on the bottom of Slider (See Figure 5-5).

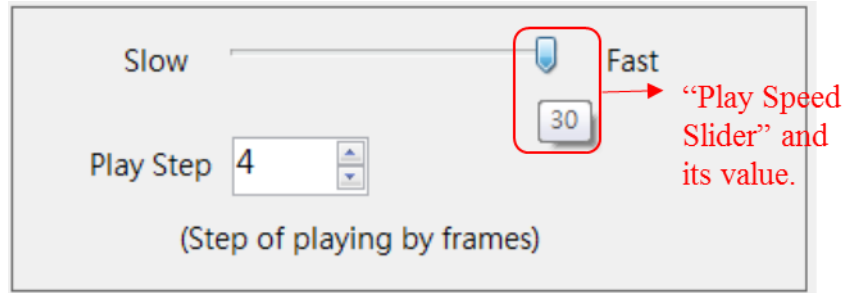

Figure 5-5 Play Speed Slider and the Corresponding Play Speed

2.4.2 Set Play Step: Use mouse to click Play Step ComboBox to set Play Step (See Figure 5-6).

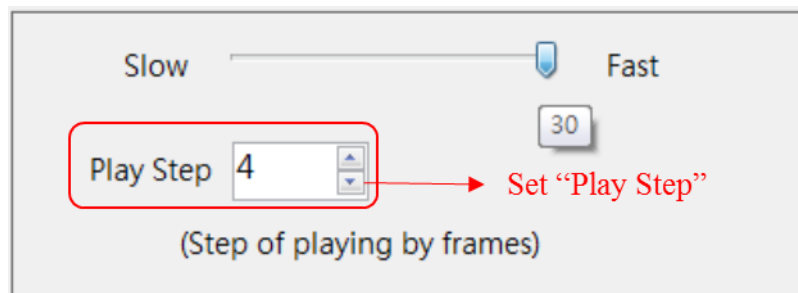

Figure 5-6 Set Play Step

2.5 Play Display Windows & Display Settings: When play back is going, user will see what is playing in Play Display Window. Besides, it supports other settings as below (See Figure 5-7).

- 2.5.1 “Fit”: Fit to Window, based on the size for Preview Window, image display size will be adjusted automatically by the program.
- 2.5.2 “1:1”: Based on the actual image size to display. Because the image size is not equal to the size of Preview Window, user may only view the part of image.
- 2.5.3 Zoom In/Out: Use mouse to click the corresponding button to enforce zoom in or zoom out (See Figure 5-7).

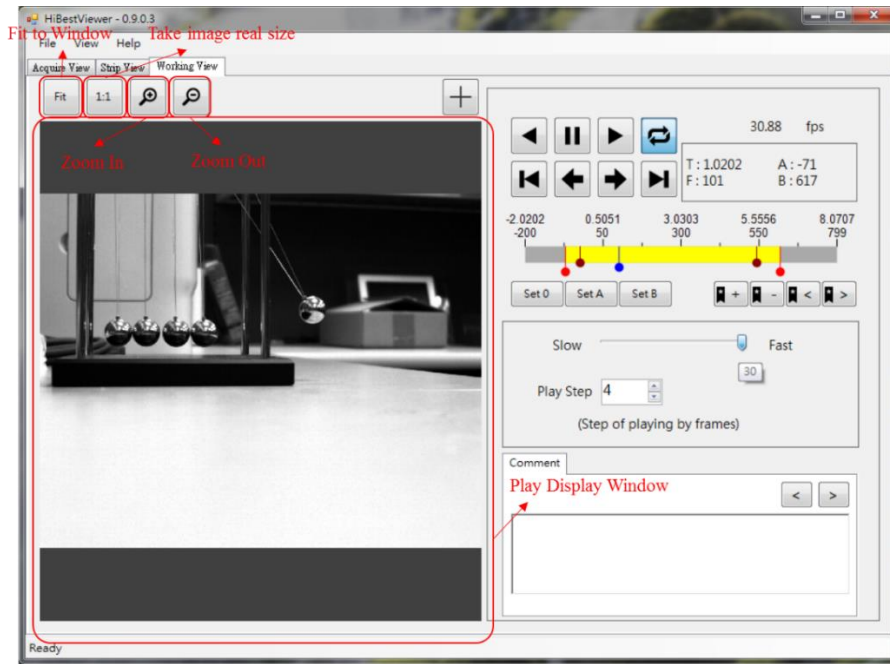

Figure 5-7 Play Display Window & Display Settings

3 Other functions in Working View

Other functions are supported: (1) Set a specified image as frame 0 (2) Set A point in A-B Play range (3) Set B point in A-B Play range (4) Add/Remove Bookmark & Move to Next/Previous Bookmark (5) Add/Modify/Remove comment & Move to Next/Previous comment (6) Display the coordinate position of image (Unit is pixel). Functions are described as follows:

3.1 Set a specified image as frame 0 (the image is specified by current Play Head position): Use mouse to click “Set 0 button”, the system will set the image where current Play Head locates as frame 0. Set as frame 0 means that set both of Frame Number and relative time as 0. At the same time, the system will revise Frame Number and relative time of all images based on “correlation sequence” (See Figure 5-8). It is the same as “Set As Zero” in Strip View” (Please refer to chapter 4 for the detailed description).

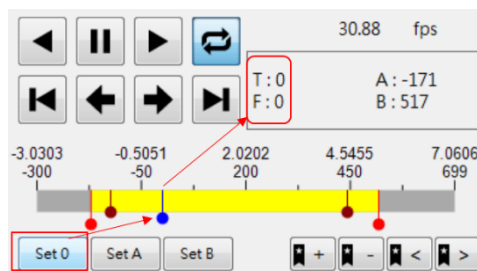

Figure 5-8 Set Play Head position as frame 0

- 3.2 Set Play Head position as A point in A-B Play range: Use mouse to click Set A button, and the system will set Play Head position as A point in A-B Play range (See Figure 5-9).

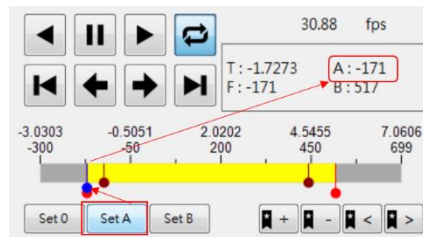

Figure 5-9 Set Play Head as A point in A-B Play range

- 3.3 Set Play Head position as B point in A-B Play range: Use mouse to click “Set B button”, and the system will set Play Head position as B point in A-B Play range (See Figure 5-10).

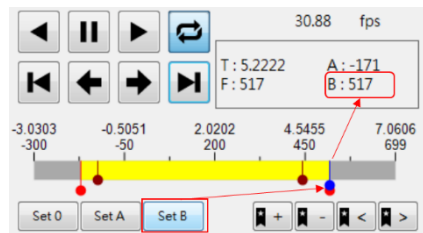



Figure 5-10 Set Play Head as B point in A-B Play range

- 3.4 Add Bookmark: Use mouse to click  button, and the system will add Bookmark on Play Head position. Nothing will happen if there is already a Bookmark on Play Head position (See Figure 5-11).

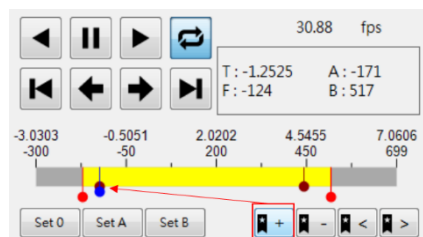



Figure 5-11 A Bookmark is added on Play Head position

- 3.5 Remove Bookmark: Use mouse to click  button, and the system will remove Bookmark on Play Head position. Nothing will happen if there is no Bookmark on Play Head position (See Figure 5-12).

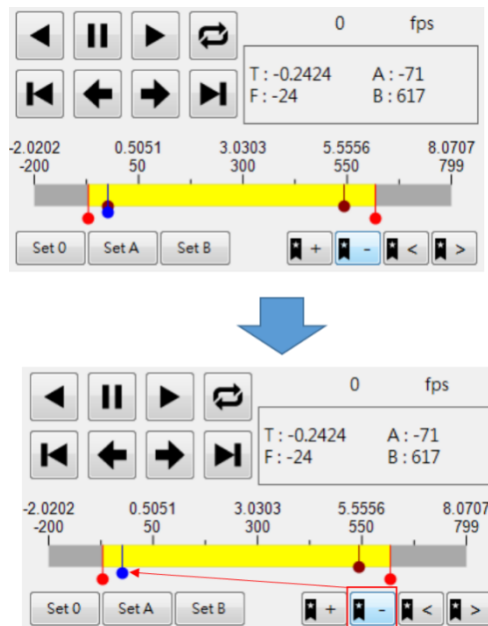



Figure 5-12 A Bookmark is removed on Play Head position

- 3.6 Move to Previous Bookmark: Use mouse to click  button. If there is a Bookmark before Play Head, the system will move Play Head to previous Bookmark. Nothing will happen if there is no Bookmark before Play Head.
- 3.7 Move to Next Bookmark: Use mouse to click  button. If there is a Bookmark after Play Head, the system will move Play Head to next Bookmark. Nothing will happen if there is no Bookmark after Play Head.
- 3.8 Add/Modify/Remove Comment: User can add, modify, and remove comment on the specified image (the image is specified by current Play Head position). Descriptions are as below:
 - 3.8.1 Move Play Head to the specified image. User can check Play Status Information any time to confirm the current Play Head position. User can drag Play Head to nearby the specified image, and use “Forward Step Play” or “Reverse Step Play” in order to move Play Head to the target position. Take Figure 5-13 for example, make a comment at Frame Number 100.
 - 3.8.2 Comment Editor Area: Write down comments on the images, including modify or remove existing comments. Take Figure 5-13 for example, it is written down “This is a test!” at Frame Number 100.

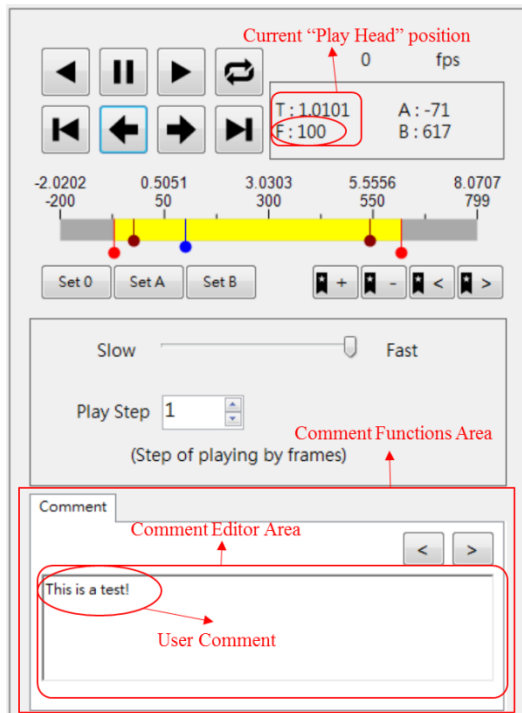

Figure 5-13 Add/Modify/Remove Comment

- 3.9 Move to Previous Comment: Use mouse to click button, and move to previous comment. If there is a comment before Play Head, the system will move Play Head to the marked position and the comment will be shown on Comment Editor Area. Nothing will happen if there is no comment before Play Head.
- 3.10 Move to Next Comment: Use mouse to click button, and move to next comment. If there is a comment next to Play Head, and the system moves Play Head to the marked position and the comment will be shown on Comment Editor Area. Nothing will happen if there is no comment next to Play Head.
- 3.11 Display the position coordinate (Unit is pixel): Turn on “Cross Line button” to get the position coordinate of a specified image, and descriptions are as below:
- 3.11.1 Use mouse to click button to turn on/off “Cross Line button”. After turning on it, user can see a blue Cross Line shown on Display Window, and the coordinate value of Cross Point will be also shown on the upper right corner (See Figure 5-14). If want to turn off it, just click button again.

3.11.2 Use mouse to click anywhere on Play Display Window to move Cross Point to the position which mouse clicks, and its coordinate value will change to the new position.

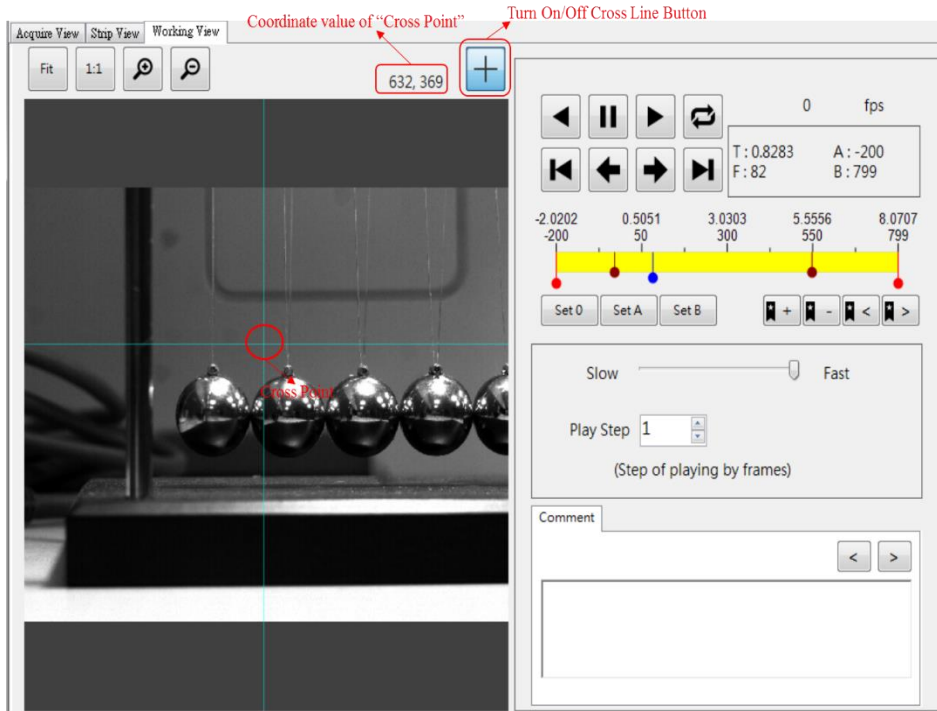

Figure 5-14 Display the Coordinate of the Specified Position

Chapter 6 Hardware Installation

1. Installing the J i j /Urggf 'Camera'REG/J UE'3882

Install a PCI express x1 Gen2 host adapter USB3.0 Card, if there is no USB3.0 ports of PC. (Option)



* PCI Express USB 3.0 Card

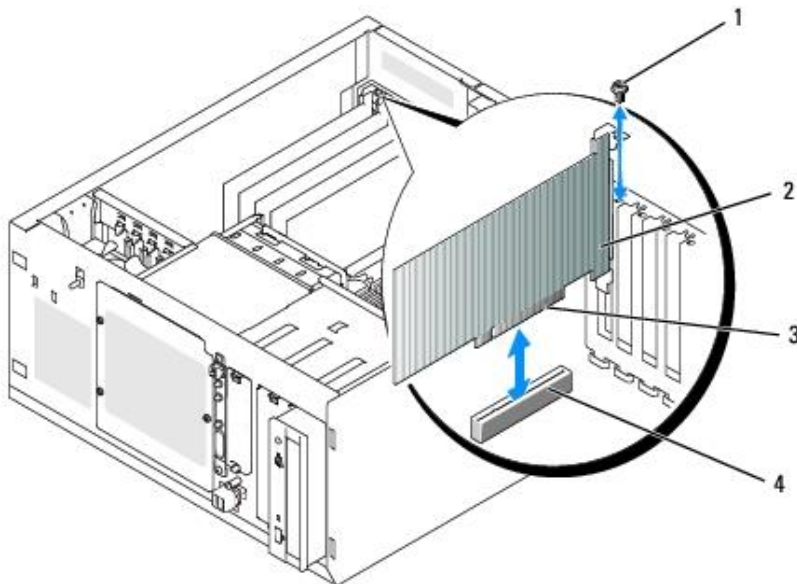

* Install PCI Express USB 3.0 Card into PCI Express Slot, be operated by professionals.

The camera is mounted on the tripod, using the mount point of the High-Speed Camera.

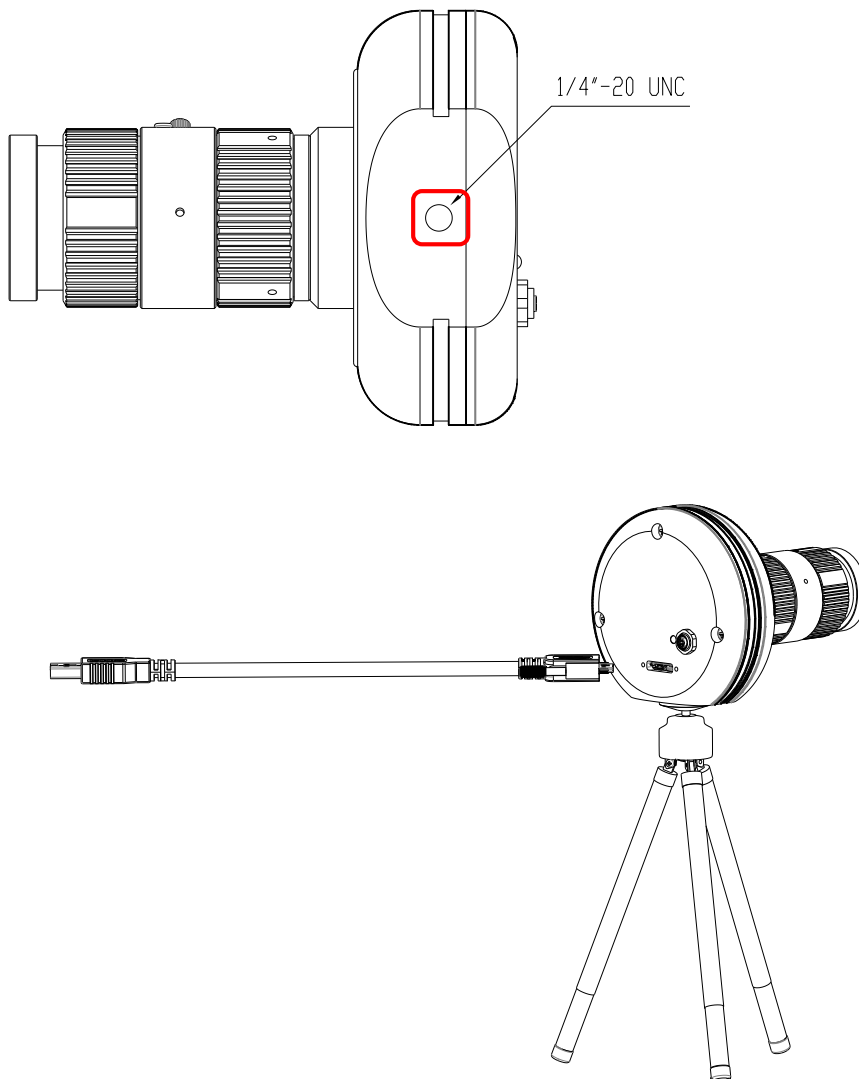

Connect the USB 3.0 Micro-B Head of the USB 3.0 Cable to the High-Speed Camera PCE-HSC 1660, tighten thumbscrews locks for a secure connection. Connect the USB Type A Head of the USB 3.0 Cable to the USB 3.0 Type A port of PC.



* High-Speed Camera PCE-HSC 1660 USB 3.0 Cable, Left Type A Connector, Right Micro-B Connector.

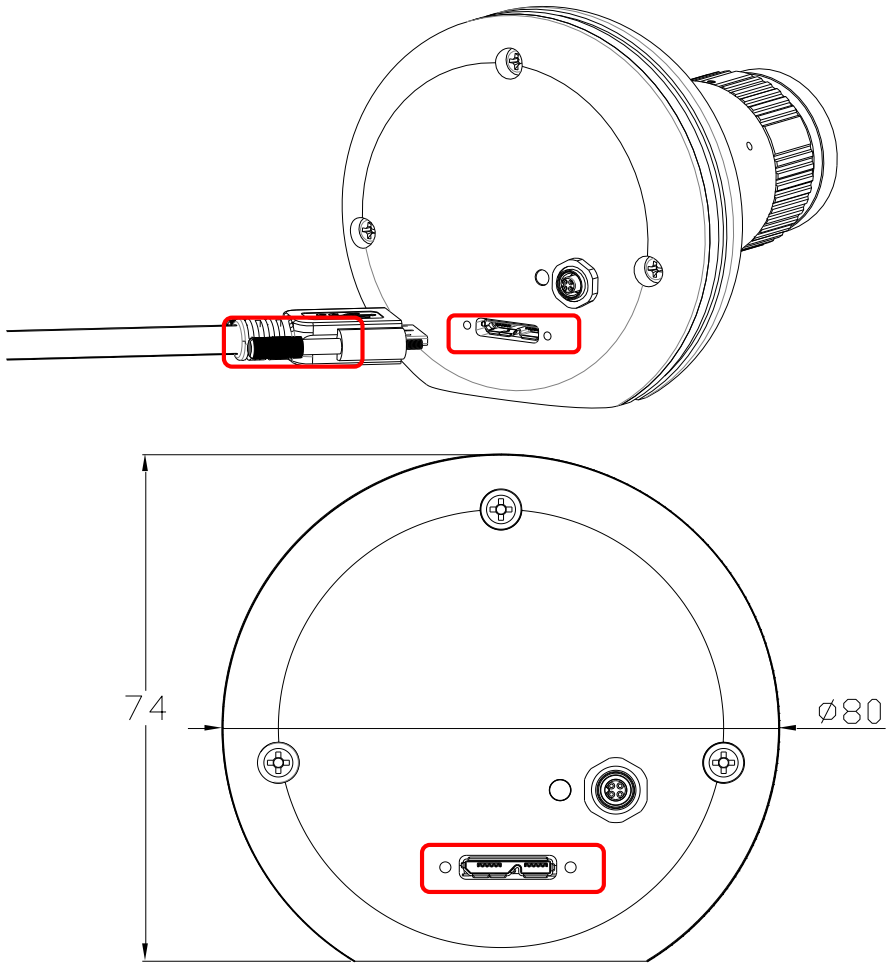

The USB 3.0 Micro-B Port with two thumbscrew holes.

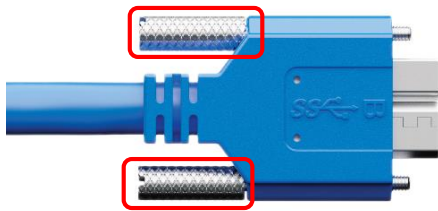

* The USB 3.0 Micro-B Cable with two thumbscrews.



* USB 3.0 Type A Port of PC (USB 3.0 Blue Connectors)



* The Diagram of the High-Speed Camera PCE-HSC 1660 System

Power Indicator Green LED now is lighting.

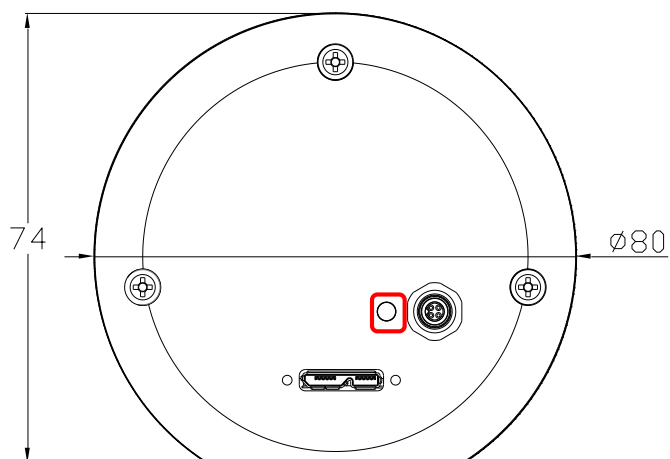

Run the Software Suite of the Camera in the PC.

Take off the cover of the lens. To get better image, please turn the aperture and the focal length of the camera by moving the sticks.

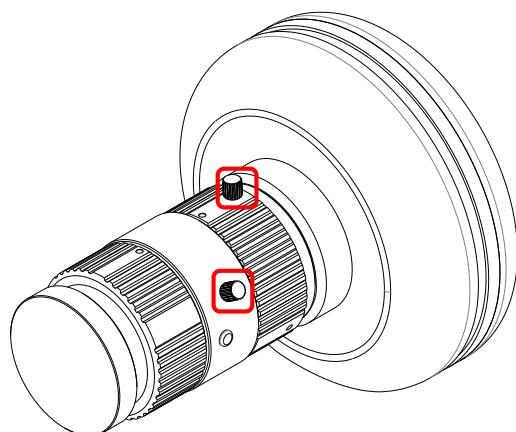

Press the button of the external trigger cable to Capture Image.

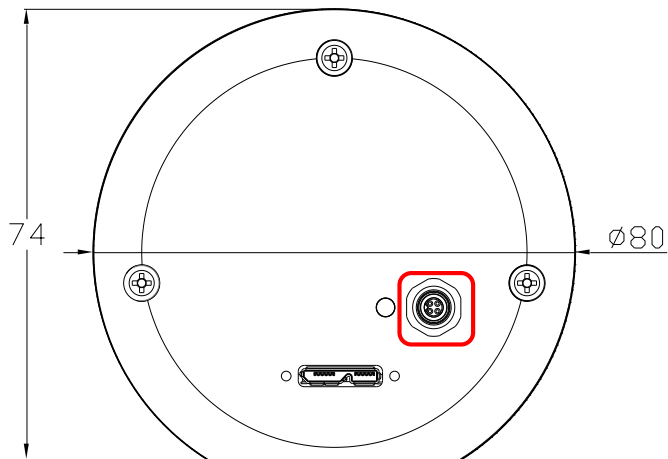

Notes:

Please use a USB 3.0 Cable, 3 meter maximum.

The High-Speed Camera PCE-HSC 1660 is compatible with all C-mount lenses with respect to imager size.

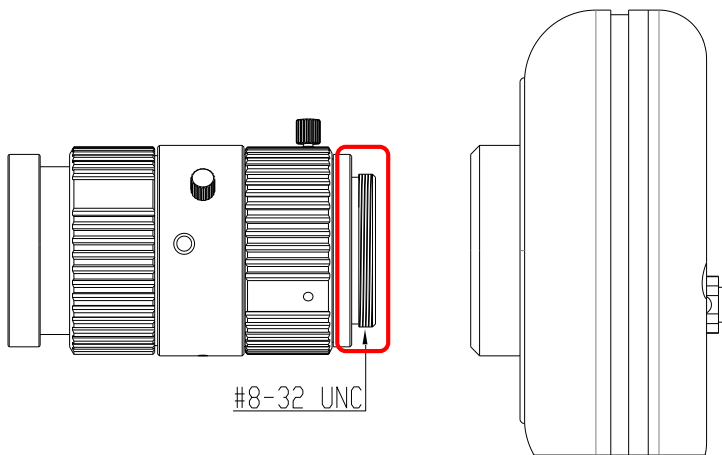

The photo marked * is reference only.