



Tursdale Technical Services Ltd
Unit N12B
Tursdale Business Park
Co. Durham
DH6 5PG
United Kingdom
Phone: +44 (0) 191 377 3398
Fax: +44 (0) 191 377 3357
info@tursdaletechnicalservices.co.uk
<http://www.industrial-needs.com/>

Manual PCE-UV34



Storage for the " UV sensor "

UV sensor is with extremely precise structure. Once don't use it , be sure to store it in the dry environment. For example, put the whole sensor including Desiccant (Drier) into to the Plastic bag and seal the bag as tightly as possible (refer the following figure).



Take the sensor out of the bag only when use it.

Comply to above method will extend the life of UV sensor. Otherwise, the gain of the UV SENSOR may be decreased and shorten the calibration period. It is also necessary to replace the Desiccant (Drier) periodically.

TABLE OF CONTENTS

1. FEATURES.....	1
2. APPLICATIONS.....	1
3. SPECIFICATIONS.....	2
4. FRONT PANEL DESCRIPTION.....	4
4-1 Display.....	4
4-2 Power Button.....	4
4-3 Hold Button.....	4
4-4 REC Button.....	4
4-5 2 mW/cm ² Button (Zero Button).....	4
4-6 20 mW/cm ² Button.....	4
4-7 Probe input socket.....	4
4-8 Battery Compartment/Cover.....	4
4-9 Stand.....	4
4-10 Tripod Fix Nut.....	4
4-11 RS-232 Output Terminal.....	4
4-12 DC 9V Power Adapter Input Socket.....	4
4-13 UV Probe Handle.....	4
4-14 UV Sensor.....	4
4-15 UV Probe Plug.....	4
5. MEASURING PROCEDURE.....	5
6. MEASURING CONSIDERATION.....	6
7. RS232 PC SERIAL INTERFACE.....	7
8. BATTERY REPLACEMENT.....	9

1. FEATURES

- * Professional, high quality UV meter.
- * Ultra-violet irradiation measurement for UVA & UVB.
- * UV detector spectrum from 290 nm to 390 nm.
- * Two ranges : 2 mW/cm², 20 mW/cm².
- * Exclusive UV sensor structure.
- * Sensor with cosine correction filter.
- * Build Zero button.
- * Microprocessor circuit provides high reliability and durability.
- * Separate UV LIGHT probe allows user to measure the UV light at an optimum position.
- * LCD display, easy readout.
- * RS-232/USB computer interface.
- * DC 9V battery power supply.
- * Build in DC 9V power adapter input socket.
- * Heavy duty & compact housing case.

2. APPLICATIONS

Industrial

- * Monitoring blue light radiation hazards in welding.
- * UV sterilization
- * Graphic arts.
- * Photochemical matching.
- * UV EPROM erasure.
- * Photoresist exposure.
- * Curing of inks, adhesives and coatings.

Laboratory

- * Weathering " degradation studies."
- * UV sterilization
- * Virology.
- * Microbial genetics.
- * DNA research. * Biologic hoods.
- * General laboratory use.

3. SPECIFICATIONS

Display	LCD size : 51 mm x 37 mm. Maximum indication 1999 counts.
Measurement ranges & resolution	<i>Range 1 : 2 mW/cm² :</i> 1.999 mW/cm ² x 0.001 mW/cm ² <i>Range 2 : 20 mW/cm² :</i> 19.99 mW/cm ² x 0.01 mW/cm ²
UV sensor spectrum	Band pass 290 nm to 390 nm.
Accuracy	± (4 % FS + 2 dgt). FS : full scale * <i>Calibration is executed under the UVA light & and compare with the standard UVA light meter.</i> * <i>Spec. tested under the environment RF Field Strength less than 3 V/M & frequency less than the 30 MHz only.</i>
Sensor structure	The exclusive UV photo sensor with the cosine correction filter.
Buttons	Power button, Hold button, REC button, Range button, Zero button.
Sample Time	Approx. 1 sec.
Over Range indication	Indication of " - - - - - ".
Weight	383 g / 0.55 LB (including battery)
Data Output	RS 232/USB PC serial interface.
Operating Temperature	0 to 50 °C.
Operating Humidity	Less than 85% R.H.
Power Supply	DC 9V battery, 006P , MN 1604 (PP3) or equivalent. DC 9V adapter input. <i>@ AC/DC power adapter is optional.</i>
Power Consumption	Approx. DC 6 mA.

Size	<i>Main instrument :</i> 200x68x30 mm (7.9x2.7x1.2 inch).
	<i>Sensor probe head :</i> 45 mm dia x 32 mm.
	<i>Sensor probe handle :</i> 125 x 24 mm dia.
Accessories Included	Instruction manual..... 1 PC. UV sensor probe..... 1 PC.
Optional Accessories	AC to DC 9V adapter. RS232 cable, UPCB-02. USB cable, USB-01. Data Acquisition software, SW-U801-WIN. Soft carrying case, CA-05A. Hard carrying case, CA-06.

4. FRONT PANEL DESCRIPTION

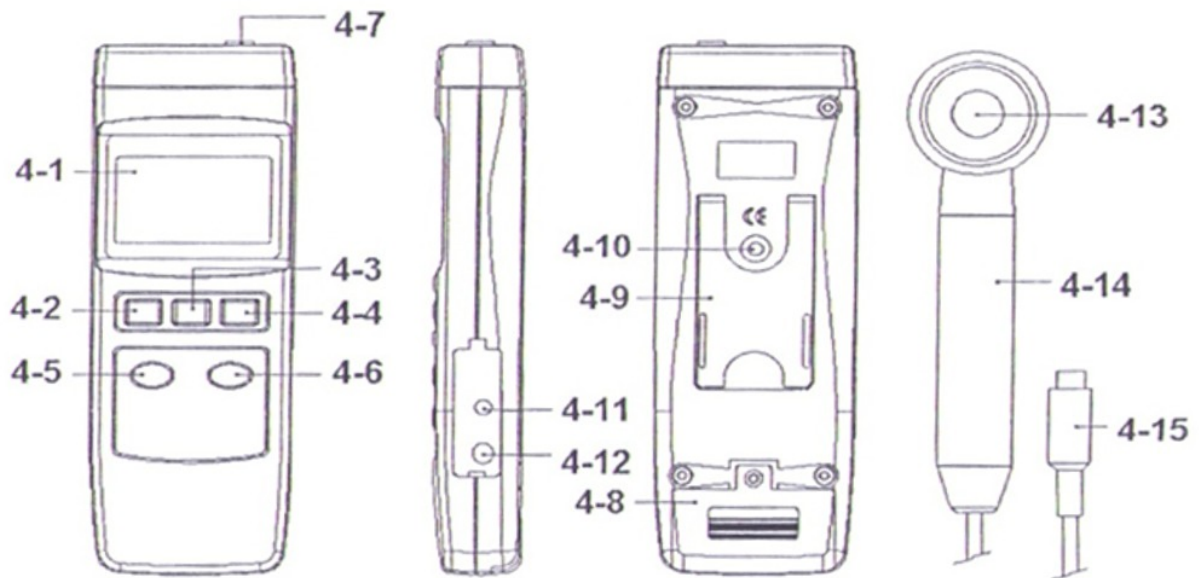

Fig. 1

- 4-1 Display
- 4-2 Power Button
- 4-3 Hold Button
- 4-4 REC Button
- 4-5 2 mW/cm² Button (Zero Button)
- 4-6 20 mW/cm² Button
- 4-7 Probe input socket
- 4-8 Battery Compartment/Cover
- 4-9 Stand
- 4-10 Tripod Fix Nut
- 4-11 RS-232 Output Terminal
- 4-12 DC 9V Power Adapter Input Socket
- 4-13 UV Probe Handle
- 4-14 UV Sensor
- 4-15 UV Probe Plug

5. MEASURING PROCEDURE

- 1) Connect the " Probe Plug " (4-15, Fig. 1) to the " Input Socket " (4-7, Fig. 1)
- 2) Power on by pushing the " Power Button " (4-2, Fig. 1).
** After power ON if push the " Power Button (4-2, Fig. 1) once a while again will power OFF the meter.*
- 3) Range selection
 - a. Select the " 2 mW/cm² " range by pushing the " 2 mW/cm² Button " (4-5, Fig. 1).
 - b. Select the " 20 mW/cm² " range by pushing the " 20 mW/cm² Button " (4-6, Fig. 1).
- 4) Use the hand to hold the " UV Probe Handle " (4-14, Fig. 1) and face the " UV Sensor " (4-13, Fig. 1) to the measuring UV light opposite. then the Display (4-1, Fig. 1) will show light values exactly.

5) Data Hold

During the measurement, pressing the " Hold Button " (4-3, Fig. 1) will freeze the display value, at the same time the LCD will show the " HOLD " indicator.

To release the Data Hold function, just pressing the " Hold Button " again, then the " HOLD " indicator will be disappeared and cancel the Data Hold function.

6) Data Record (Max., Min. reading)

- * The data record function records the maximum and minimum readings. Press the " REC Button " (4-4, Fig. 1) once to start the Data Record function and there will be a " REC. " symbol on the display.
- * With the " REC. " symbol on the display :
 - a) Press the " REC Button " (4-4, Fig. 1) once, the " REC. MAX. " symbol along with the maximum value will appear on the display.
If intend to delete the maximum value, just press the " Hold Button " (4-3, Fig. 1) once, then the display will show the " REC. " symbol only & execute the memory function continuously.

- b) Press the " REC Button " (4-4, Fig. 1) again, the " REC. MIN. " symbol along with the minimum value will appear on the display.
If intend to delete the minimum value, just press the " Hold Button " (4-3, Fig. 1) once, then the display will show the " REC. " symbol only & execute the memory function continuously.
- c) To exit the memory record function, just press the " REC " button for 2 seconds at least. The display will revert to the current reading.

6. MEASURING CONSIDERATION

- 1) As the " 20 mW/cm² range " is designed & to measure the UV light values more than 2 mW/cm² . If the measured UV light values more than 2 mW/cm², it should select to the " 20 mW/cm² range " to get the exact measuring value.

** Under the " 2 mW/cm² range " if the " Display show " " ---- " , it means the measurement value already over range, it should select to the " 20 mW/cm² range).*

2) **Zero adjustment**

Cover (blank) the " UV Sensor " (4-13, Fig, 1), pushing " Zero Button /2 mW/cm² Button " (4-5, Fig. 1) continuously at least 3 seconds, LCD will reach to zero values.

Note :

Zero Button (4-12, Fig. 1) can be operated under the display value ≤ 0.1 mW/cm² only.

3) Storage for the " UV sensor "

UV sensor is with extremely precise structure. Once don't use it , be sure to store it in the dry environment. For example, put the whole sensor including Desiccant (Drier) into to the Plastic bag and seal the bag as tightly as possible. Take the sensor out of the bag only when use it. Comply to above method will extend the life of UV sensor. Otherwise, the gain of the UV SENSOR may be decreased and shorten the calibration period. It is also necessary to replace the Desiccant (Drier) periodically.

7. RS232 PC SERIAL INTERFACE

The instrument has RS232 PC serial interface via a 3.5 mm terminal (4-11, Fig. 1).

The data output is a 16 digit stream which can be utilized for user's specific application.

A RS232 lead with the following connection will be required to link the instrument with the PC serial port.

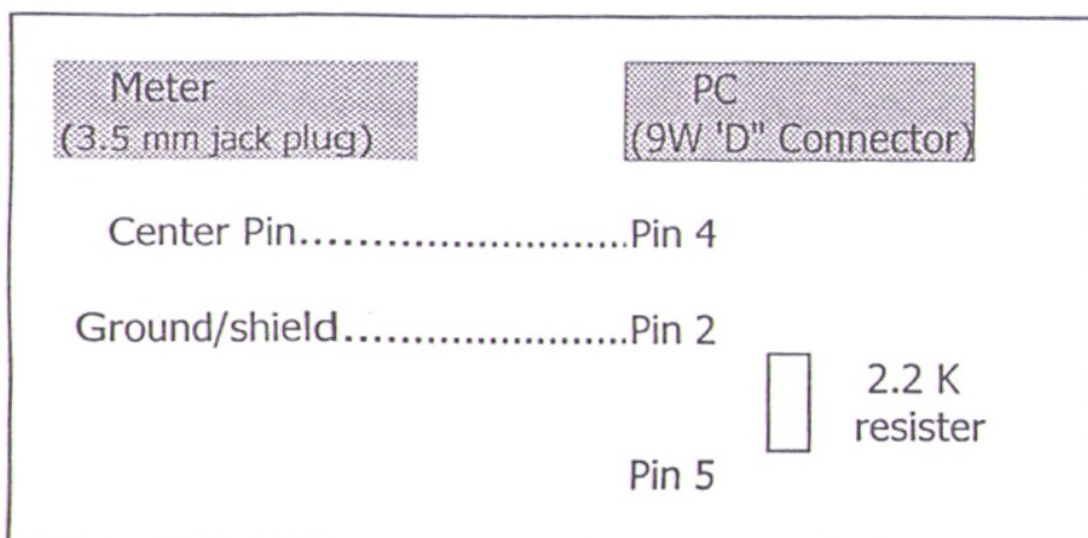

The 16 digits data stream will be displayed in the following format :

D15 D14 D13 D12 D11 D10 D9 D8 D7 D6 D5 D4 D3 D2 D1 D0

Each digit indicates the following status :

D15	Start Word = 02
D14	4
D13	1
D12 & D11	Annunciator for Display mW/cm ² = A8 (D12 = A, D11 = 8)
D10	Polarity 0 = Positive 1 = Negative
D9	Decimal Point(DP), position from right to the left 0 = No DP, 1= 1 DP, 2 = 2 DP, 3 = 3 DP
D8 to D1	Display reading, D8 = MSD, D1 = LSD For example : If the display reading is 1234, then D8 to D1 is : 00001234
D0	End Word = 0D

RS232 setting

Baud rate	9600
Parity	No parity
Data bit no.	8 Data bits
Stop bit	1 Stop bit

8. BATTERY REPLACEMENT

- 1) When the LCD display show the "  " indicator, it is necessary to replace the battery. However, in-spec measurement may still be made for several hours after low battery indicator appears before the instrument become inaccurate.
- 2) Open the " Battery Cover " (4-8, Fig. 1) away from the instrument and remove the battery.
- 3) Replace with 9V battery and reinstate the cover .
- 4) Make sure the battery cover is secured after change the battery.



In this direction will find a vision of the measurement technique:
<http://www.industrial-needs.com/measuring-instruments.htm>

NOTE: "This instrument doesn't have ATEX protection, so it should not be used in potentially explosive atmospheres (powder, flammable gases)."